



LB

Series

110
130



Horizontal Boring Center

Precise, Fast, Versatile



Table of Content

Overview

- 01 / 02 Cover / Table of Content / Description
- 03 / 04 Full Machine

Structure

- 05 Spindle Head Design
- 06 Machining Performance
- 07 / 08 Structural Design
- 09 Product Features
- 10 Enclosure
- 11 Spindle Unit
- 12 Worktable
- 13 / 14 ATC/Magazine Unit

Ergonomics

- 15 Operating Panel / Controller

Precision Measurement

- 16 Online Measurement
- 17 Precision Inspection
- 18 Precision Grade

Application

- 19 Test Cut

Optional Features

- 20 High Performance Features
- 21 U Axis System / Optional Feature
- 22 - 25 Machine Appearance & Dimension
- 26 Technical Data



内容





Assembly Factory

To achieve the high precision requirement, a factory was built specifically for the production of the boring centers with foundation that meets the standard.

Horizontal Boring Machining Centers

Reverse T Structure, Moving Column (Z Axis) Design

LB-110

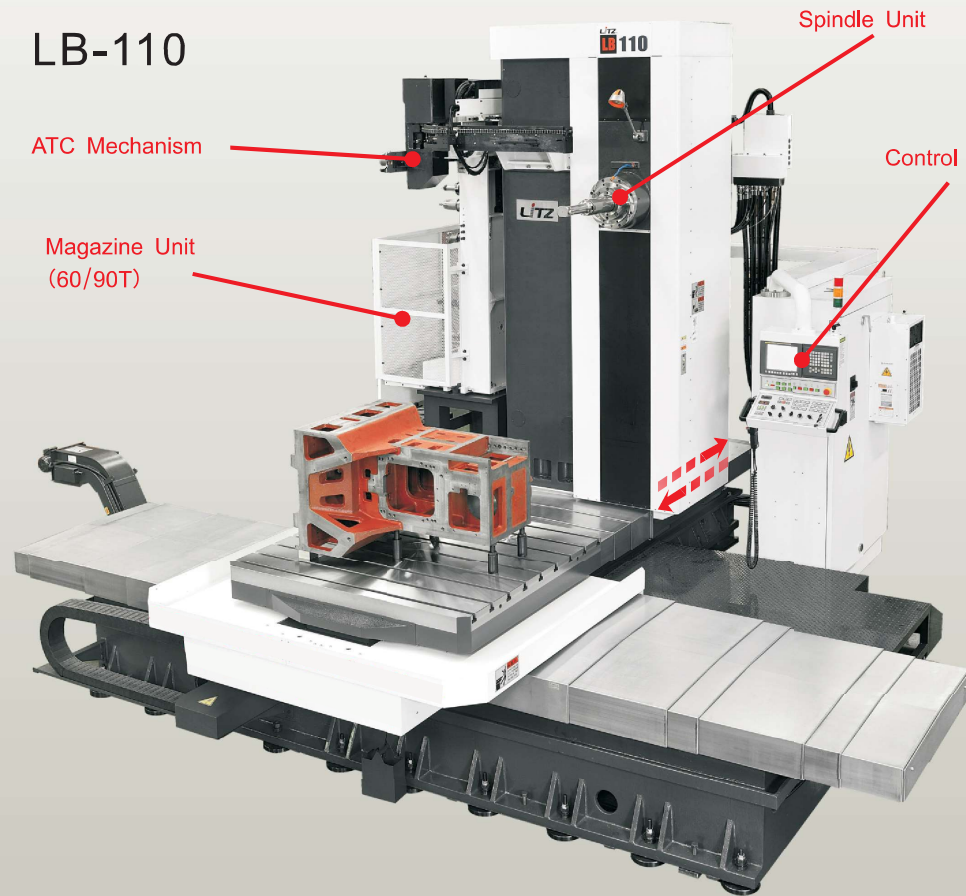

- Worktable full travel support, to ensure worktable's X axis travel straightness precision.
- Gearbox is optional for high torque output in heavy machining.
- Separate ATC and column design, to ensure column is not affected during tool changing.

Highly Dynamic Cutting Performance

LB-130

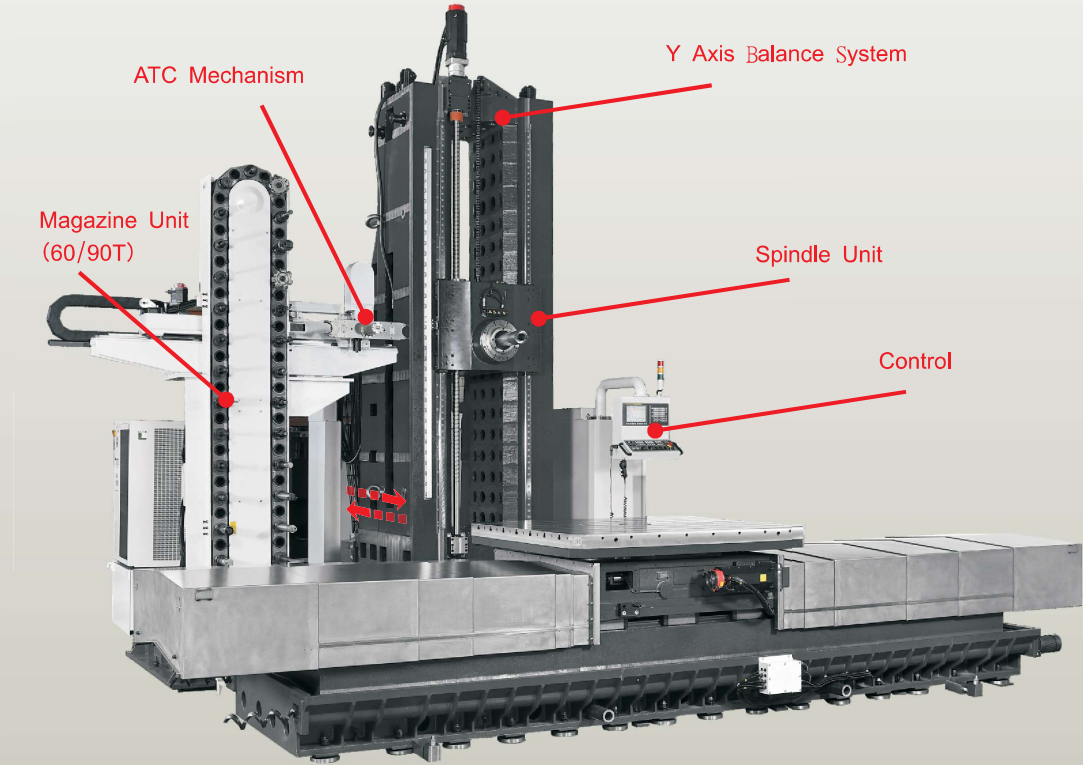

- Dual support design, extra heavy duty for loading on the worktable.
- Spindle are specifically designed for boring/milling purposes.
- Brake positioning system is employed for the worktable, providing heavy duty machining.

Highly Rigid Column & Spindle Head Mechanism

LB110 Boring Mill Center

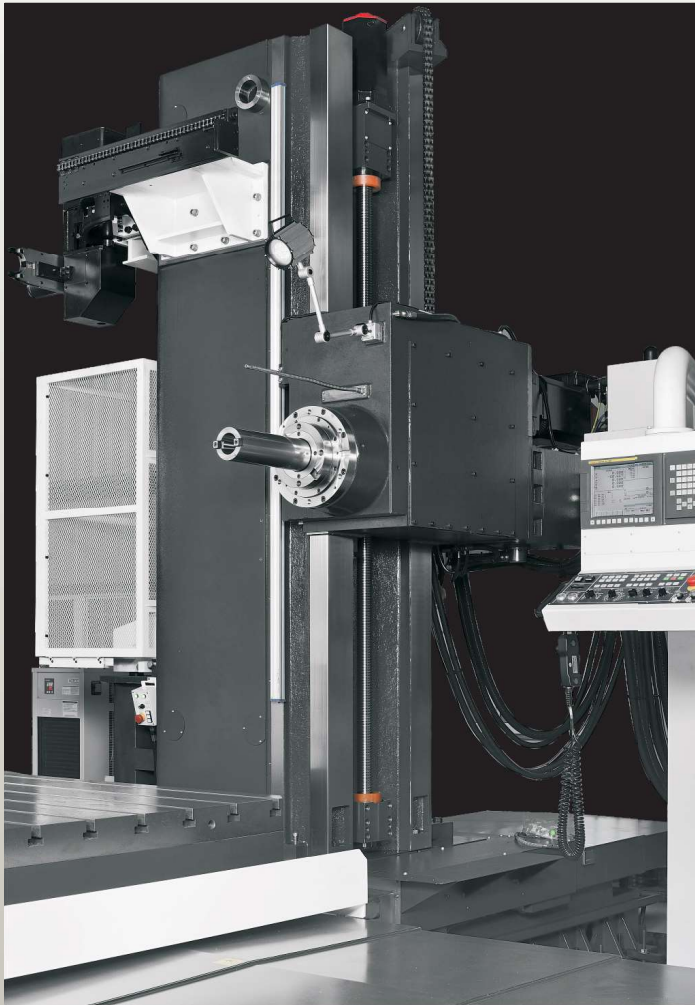

Design Highlight:

- High rigid boxway transmission.
- Side way spindle mechanism for spindle head.
- Heavy duty cutting is suitable

LB130 Boring Mill Center

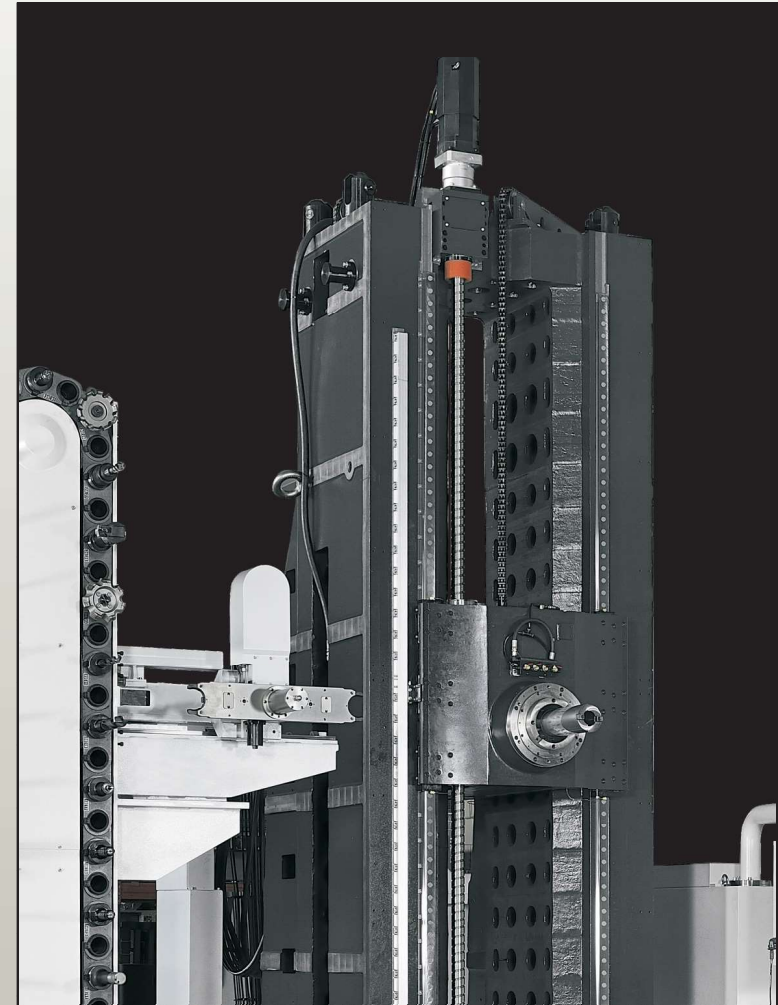

Design Highlight:

- High rigid roller-type linear guide transmission.
- Side way spindle mechanism for spindle head.
- Heavy duty cutting is suitable

In combination the advanced technology, the LB series fulfills the demand from different users for the high quality choice. The closed-type spindle mechanism design, provides high rigidity for heavy duty cutting. The X/Y/Z 3 axes is full-stroke supported with boxway guideways. Additionally high resolution linear scales ensures the high precision machining. Boring / milling / tapping / drilling tasks can be carried out easily.

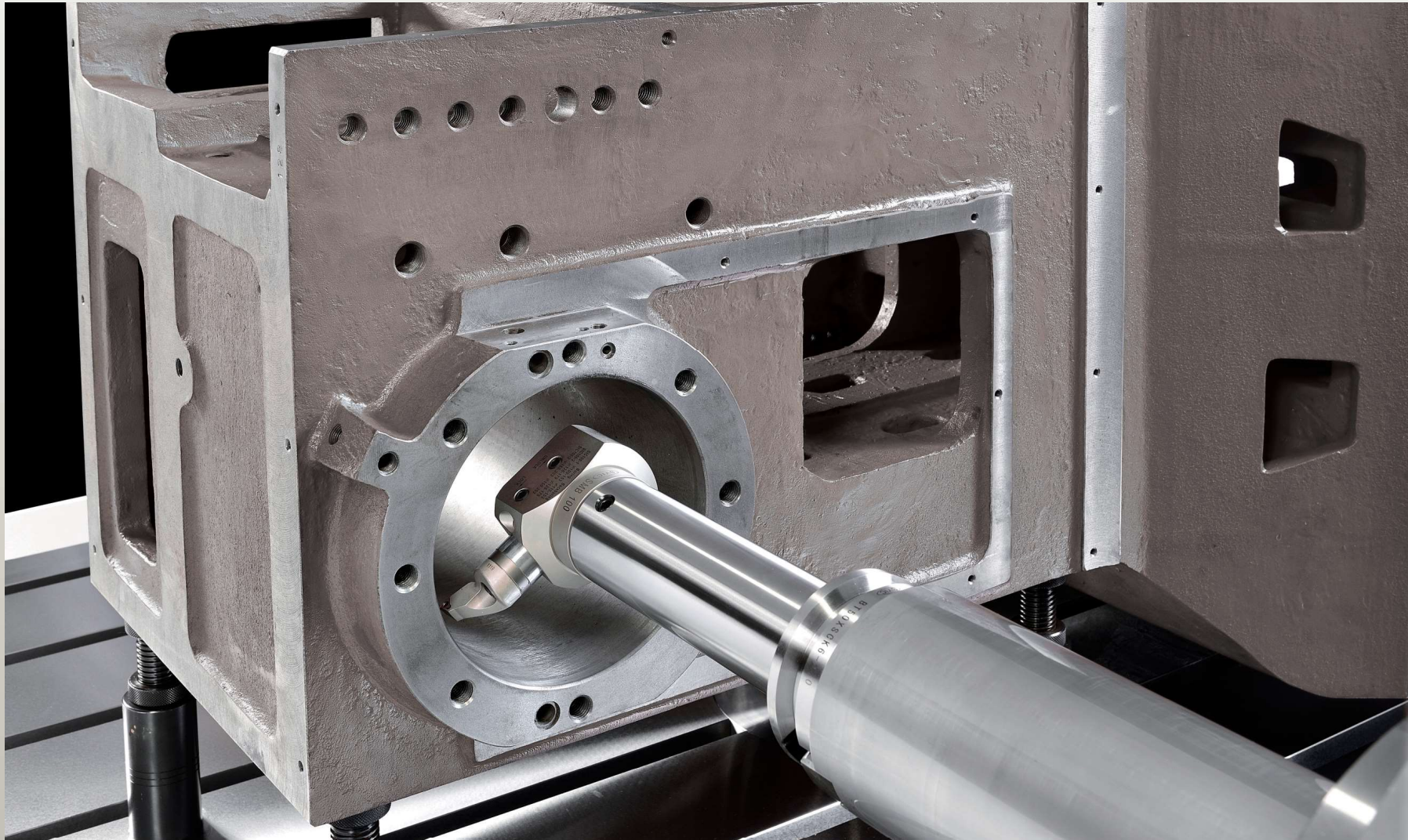

High Performance Horizontal Boring / Milling Centers

- Spindle with gearbox, can accommodate high speed cutting in moulding industry, low speed high torque can also be achieved.
- X/Y/Z/B are all with high rigid boxway, and with full stroke support design.
- Close circuit high precision 3 axes linear scales are standard for achieving high precision.
- Moving column mechanism design ensures the W axis precision can be maintained at any length of extension.
- Rotary table is equipped with servo motor, in combination with worm gear transmission and hydraulic brake system to provide stable and powerful clamping force.



(LB-110)

Optimized Structural Design

Design Highlights:

- 3 axes full stroke support with best rigidity and stability for longer precision.
- Boxway design is used for the 3 axes guideways, to significantly increase the cutting capabilities and rigidity.
- 2500RPM with 35 horsepower from the spindle's gearbox, can provide max. torque up to 1500Nm during heavy cutting. (LB-110)
- 2500RPM with 50 horsepower from the spindle's gearbox, can provide max. torque up to 2470Nm during heavy cutting. (LB-130)
- Automatic positioning for rotary table, can ensure the angle position's integrity during heavy cutting.

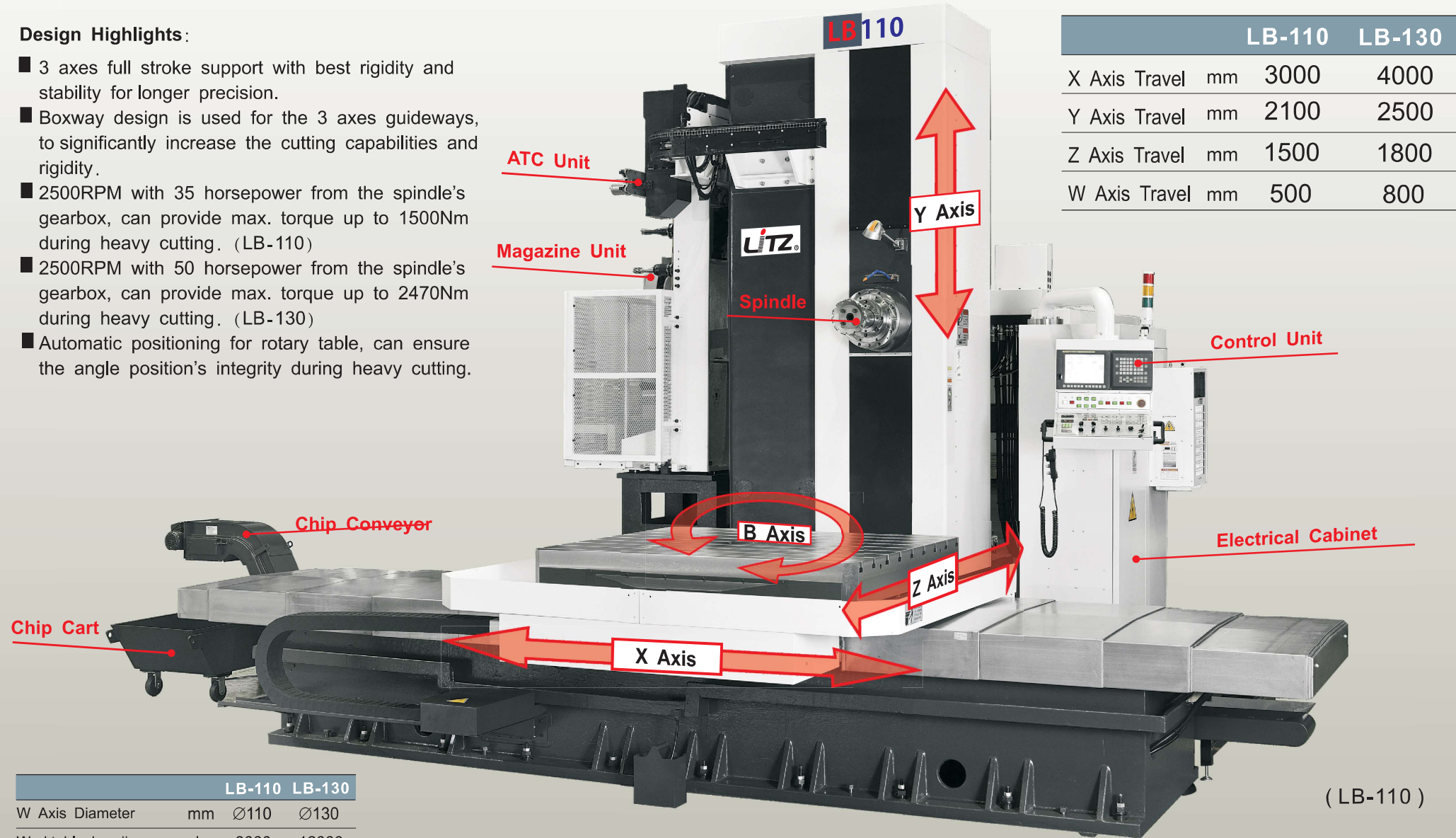

		LB-110	LB-130
X Axis Travel	mm	3000	4000
Y Axis Travel	mm	2100	2500
Z Axis Travel	mm	1500	1800
W Axis Travel	mm	500	800

		LB-110	LB-130
W Axis Diameter	mm	Ø110	Ø130
Worktable Loading	kg	8000	12000
Tool Magazine Capacity	T	60	60
Spindle Torque	Nm	1500	2470

(LB-110)



Product Highlight

■ **Heavy Loading Rotary Table**

0.001 Indexing Precision

Max. Table Loading 8000KG (LB-110)

20000KG (LB-130)

■ **Expanded Machining Area**

A varieties of spindle are provided

■ **Rapid Tool Changing System**

Arm Type Magazine

Optional 90 Tools Magazine

(LB-110 & 130)

■ **User Friendly Control Interface**

Comfortable and safe operating environment

Enclosure

Full Cover Type Enclosure

OP

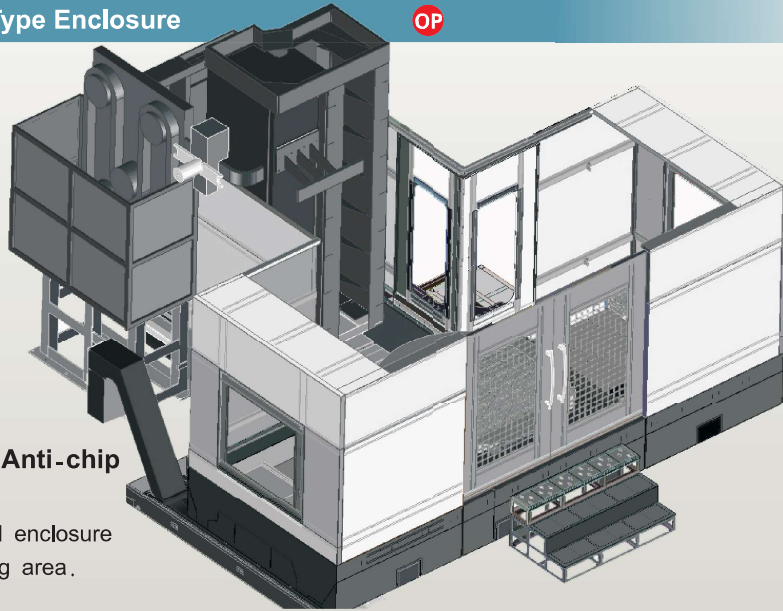

Full Cover & Anti-chip Enclosure

- Fully enclosed enclosure in the working area.

For large or long type of workpieces. Enclosure will not be affected by the load / unloading operation of the workpiece

Standard Type Enclosure LB110



Worktable Guard

OP

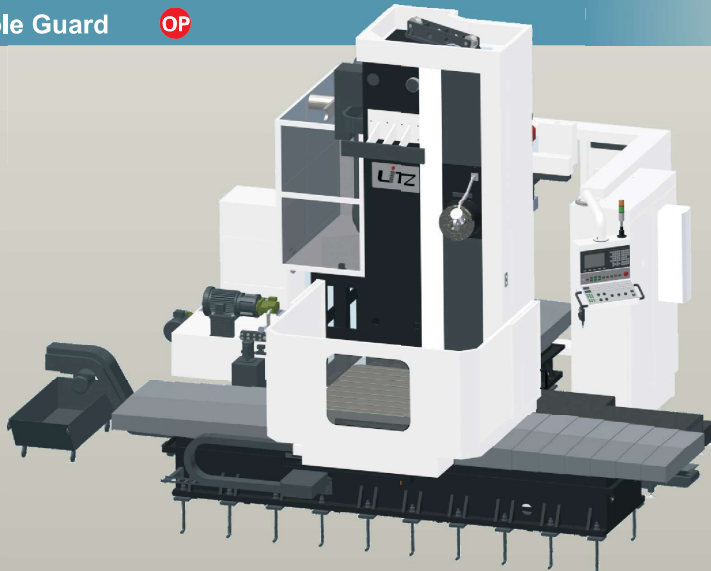

Standard Type Enclosure LB130

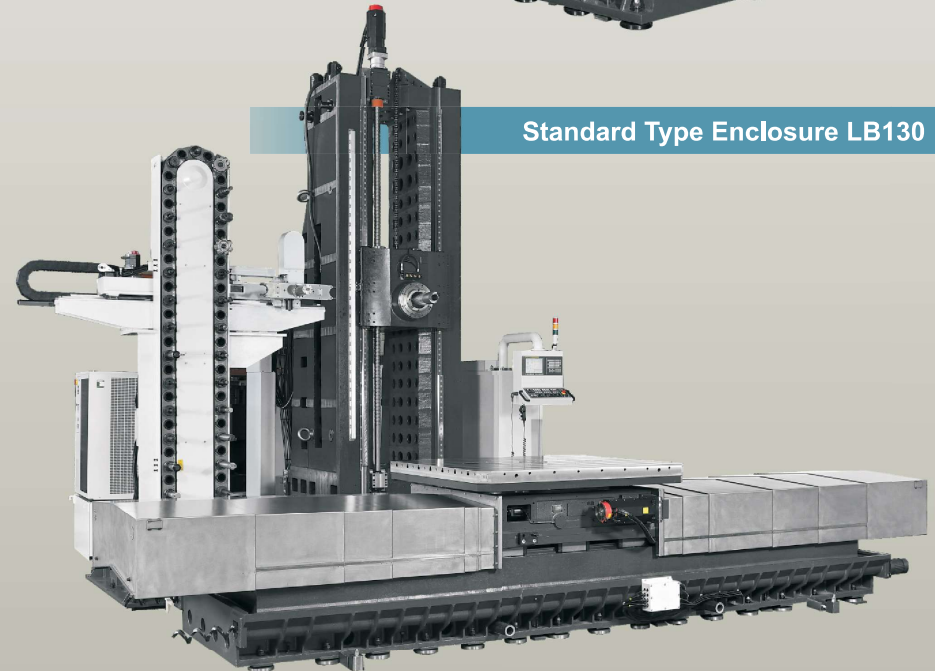

■ 工作台護罩低於工作台面，使加工的範圍加大，不因工作護罩而減少加工空間。

Spindle

W Axis



Ultra Strong Cutting Force

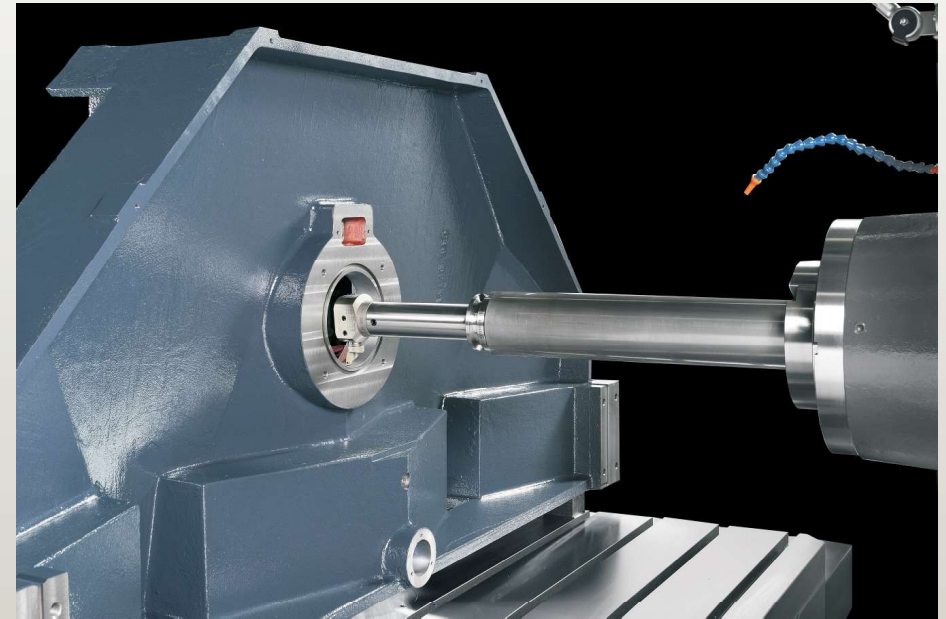

Spindle Gearbox Transmission System (S axis)

- Spindle Head From 110mm Diameter, combined with 2-step gear box, for 1500NM torque output at 165RPM. The shaft can extend out 500mm. (LB110)
- Spindle Head From 130mm Diameter, combined with 2-step gear box, for 2470NM torque output at 143RPM. The shaft can extend out 800mm. (LB110)
- Spindle cooling is done by high performance oil-cooling control.

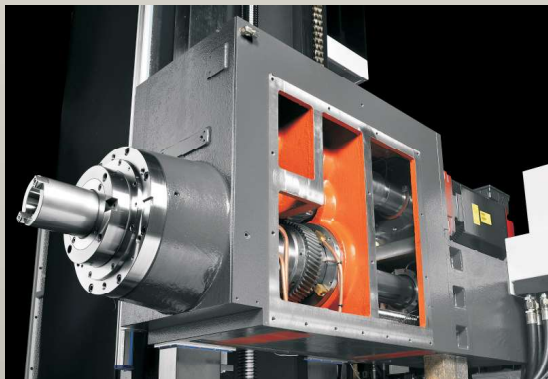

Spindle Motor Power and Torque Chart

LB - 110

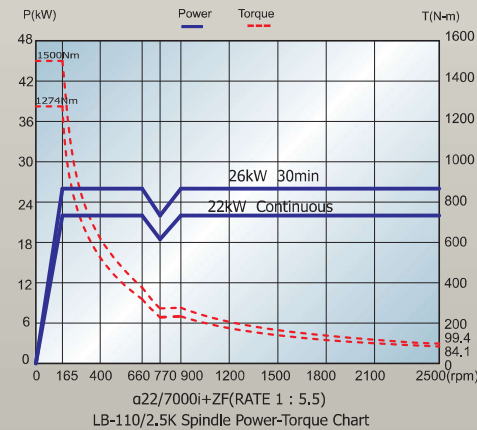

LB - 130

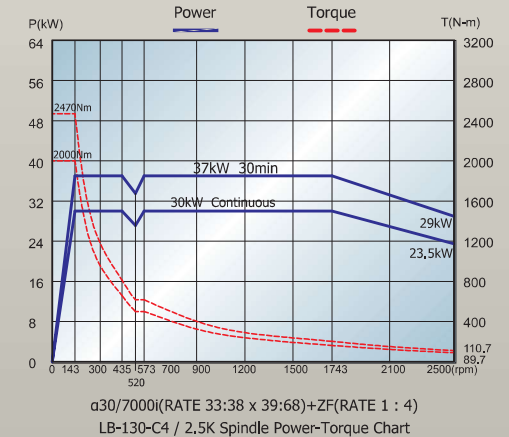

Rotary Table

Heavy loading Rotary Table

Rotary table's max. loading is

up to **8 tons** (LB110),

and **20 tons** (LB130)

Work table size: **1600x1440**mm (LB-110)

1800x2200mm (LB-130)



- The rotary table is designed with double-pinion mechanism. Max. loading is at 4 angles (0, 90, 180, 270 degrees)
- It is directly installed onto the shaft, for best precision.

Worktable Highlight

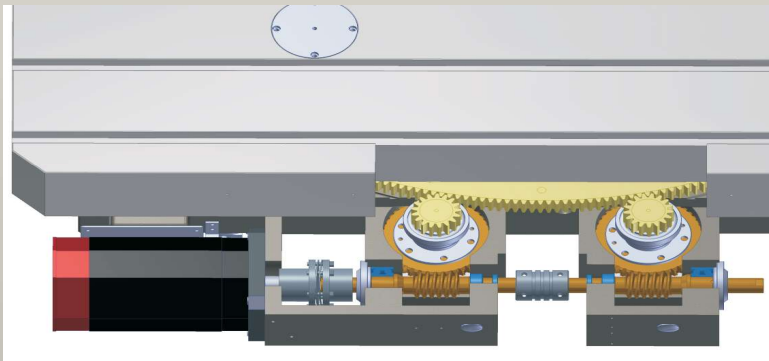

- Worktable is with ultra-large gears, in combination with worm-gear, and pretensioned to eliminate the backlashes.
- Worktable is designed with heavy-duty hydraulic system, to ensure powerful worktable clamping power.

Scraping



- Scraping techniques for even contacts in a large area, for best lubrication and low friction.

Loading Test

- Rated loading test is performed, to ensure high dynamic characteristics and precisions.

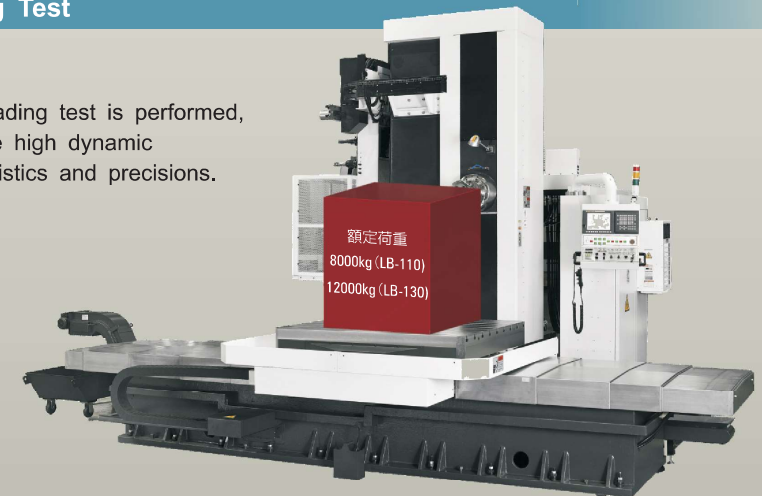

Auto Tool Changing Mechanism and Magazine Unit (LB110)

Floor - Type Magazine

LB - 110

- ATC and tool magazine unit are designed to floor type. Dynamics of the column will not be affected by the weight of the magazine and tool.
- Magazine's tool capacity can be expandable.
- Tool taper BT/CAT/DIN are available for ATC and magazine unit.

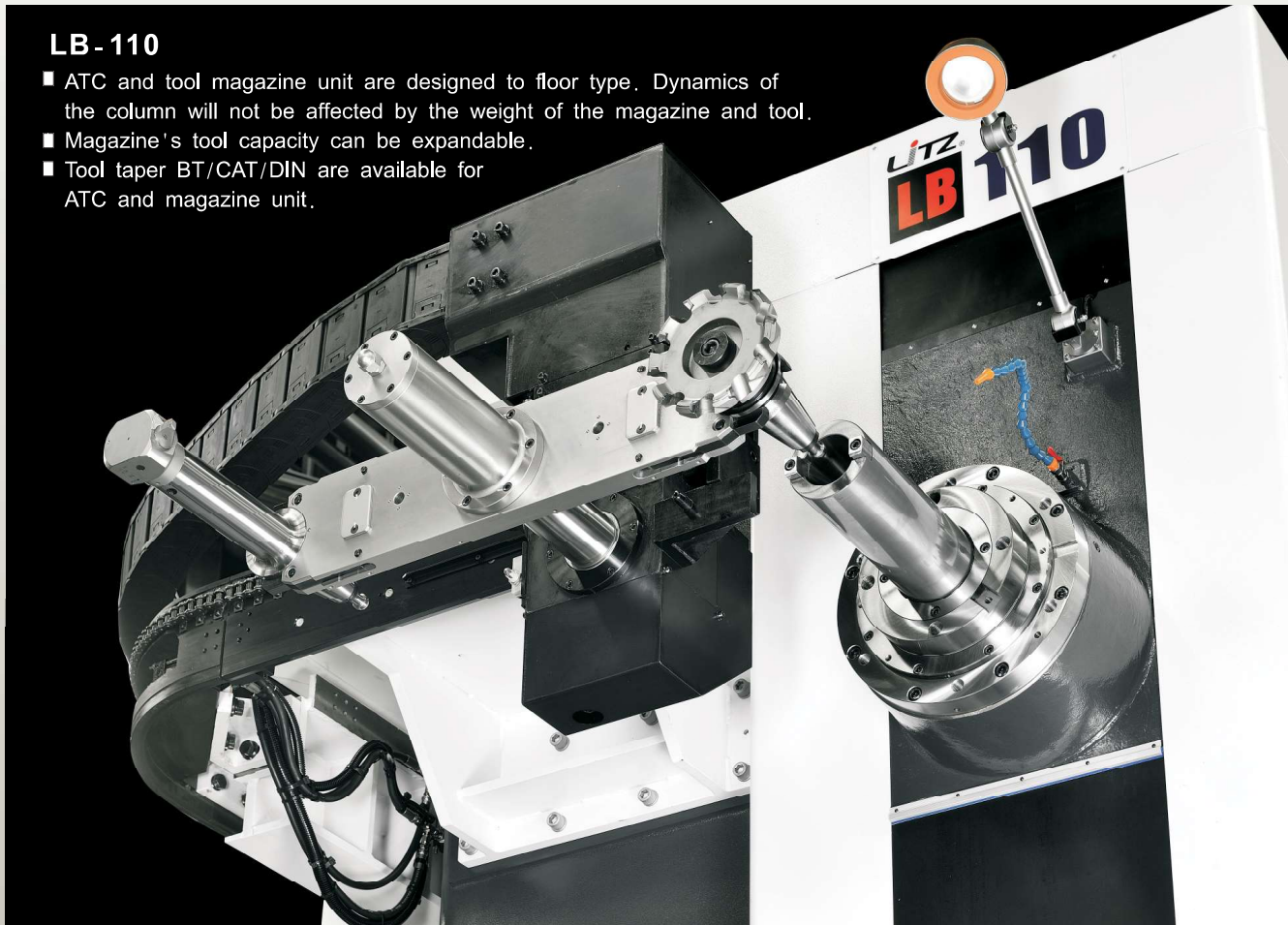

- Rapid, simple, reliable tool lifespan of the ATC.
- Unique tool changing design with random tool selection method.
- Auto tool changing mechanism passed reliability test.
- Rapid tool changing mechanism saves the non-cutting time.

Automatic Tool Changing Mechanism

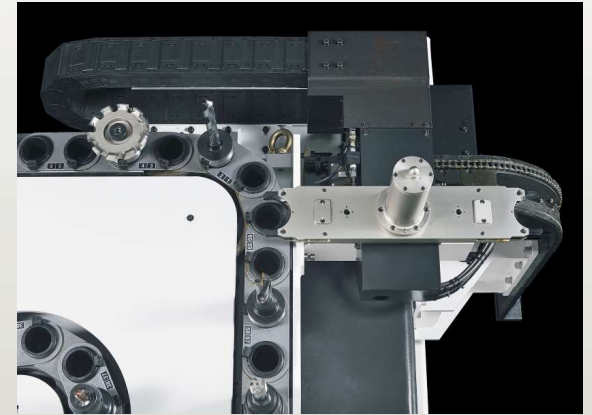

- Z axis is with moving column structure, separating magazine and column. The magazine can be expanded with tool warehouse.

Tool Magazine Unit



- 60 tools capacity.
- Large capacity magazine for high efficiencies.
- Arm-type tool changing mechanism for space saving purpose and reliability.
- Manual loading/unloading of the tool can be done easily.

Automatic Tool Changing Mechanism & Magazine Unit

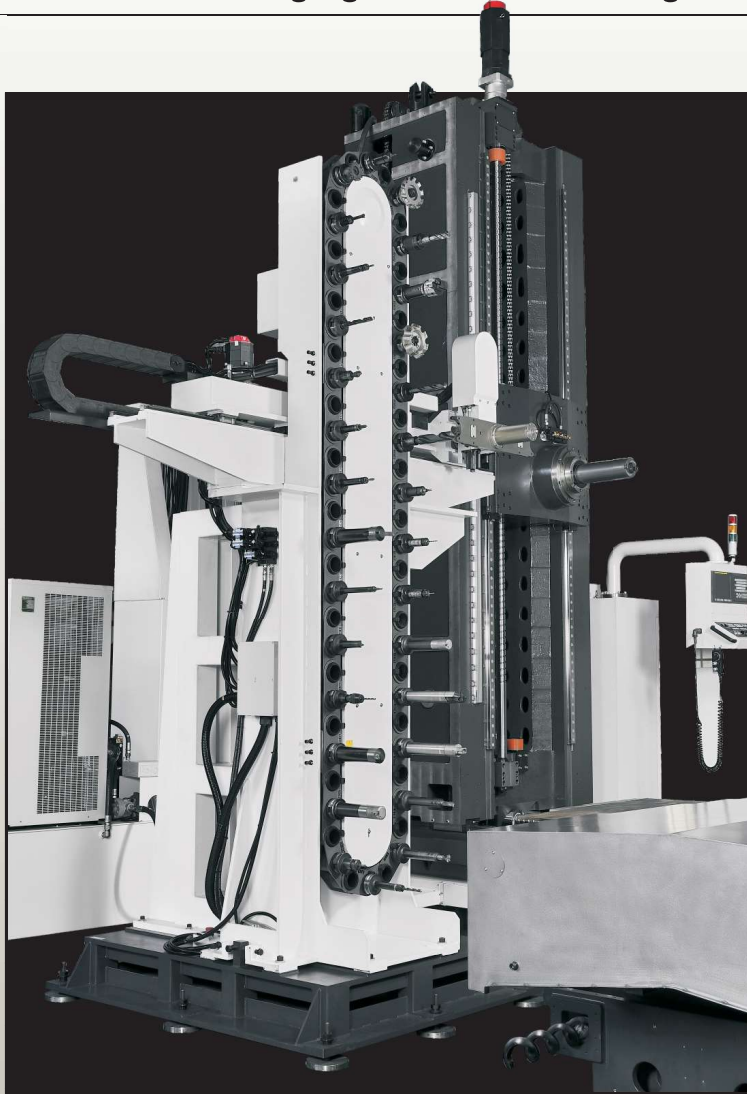

LB-130

- ATC and tool magazine unit are designed to floor type. Dynamics of the column will not be affected by the weight of the magazine and tool.
- Magazine's tool capacity can be expandable.
- Tool taper BT/CAT/DIN are available for ATC and magazine unit.

- Z axis is with moving column structure, separating magazine and column. The magazine can be expanded with tool warehouse.
- 60 tools capacity.
- Large capacity magazine for high efficiencies.
- Arm-type tool changing mechanism for space saving purpose and reliability.
- Manual loading/unloading of the tool can be done easily.

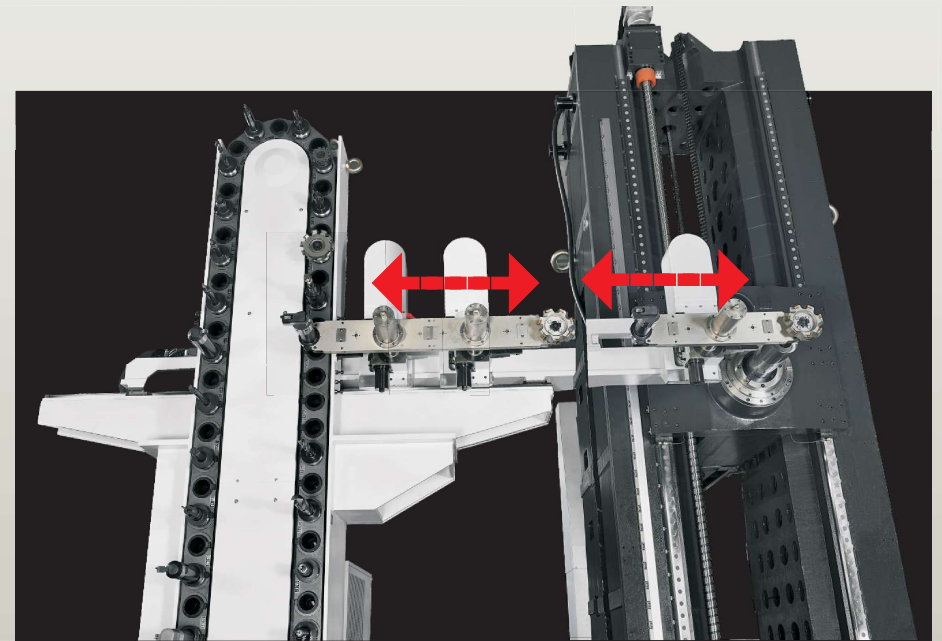

- Rapid, simple, reliable tool lifespan of the ATC.
- Unique tool changing design with random tool selection method.
- Auto tool changing mechanism passed reliability test.
- Rapid tool changing mechanism saves the non-cutting time.

User Friendly Interface

User Friendly HMI Interface



- In compliance with safety regulation and rotatable operating control, for ease of operation.

Fanuc Control Series



- Important buttons are protected by protective cover, to prevent false triggering.

User Friendly Control Panel



Jog Wheel



FANUC Series 0i-MD

特長

- Maximum Control Axes: 8
 - Max. Feed Axes: 7
 - Max. Spindle Axes: 2
 - * Simultaneous Axes: 4
 - * Aicc II
 - * Nano smoothing
 - * USB Interface
 - * Dynamic simulation

Measurement System

Tool Length Measurement **OP**

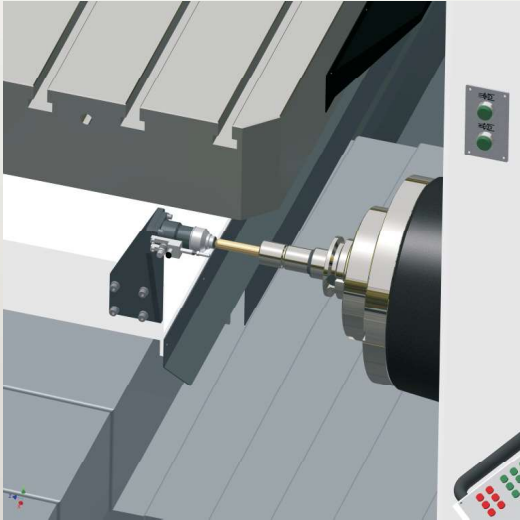

Advantages :

- Reduce the machine idle time
- High yield rate
- High productivity
- High production quality

Spindle Tool Pull Force Test



Each spindle is tested with full clamping force inspection, to ensure spindle clamping power.

- High clamping force spindle, ensures the rigidity during heavy-duty cutting.
- Spindle tool pulling force:
2100kgf (LB110)
2100kgf (LB130)
- High tool pulling force provides rigidity in all machining conditions.

Workpiece Measurement System **OP**

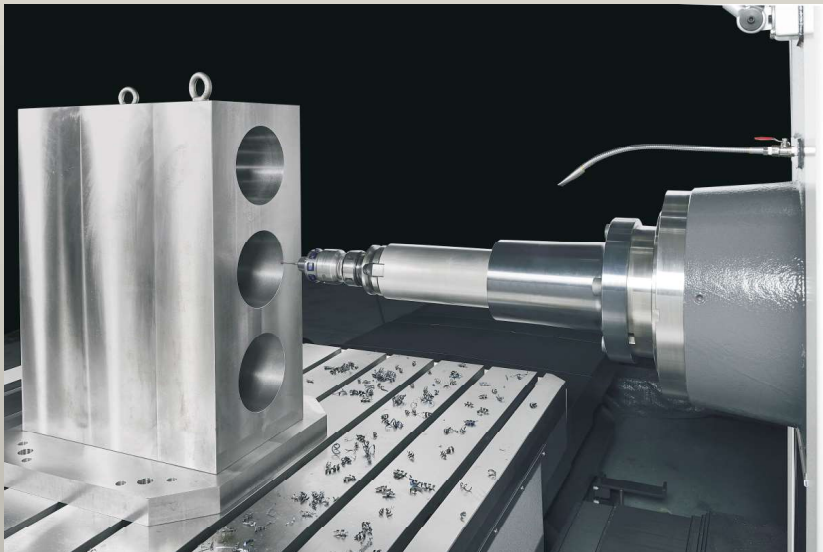

Spindle Dynamic Balance Calibration

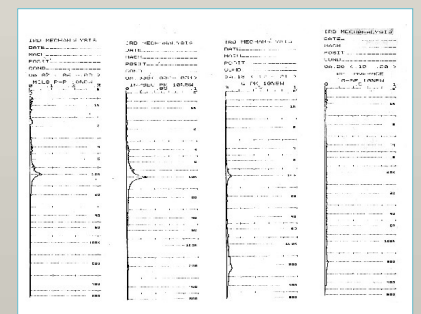

- All spindles are calibrated to ensure spindle's acceleration, movement, speed are at highest performances.

High Performance Inspection System

Linear Axes Positioning Precision (XYZ Axes)

For maximum value of the product, and in compliance with the customer demand, Litz operates within a set of strict quality assurance procedure.

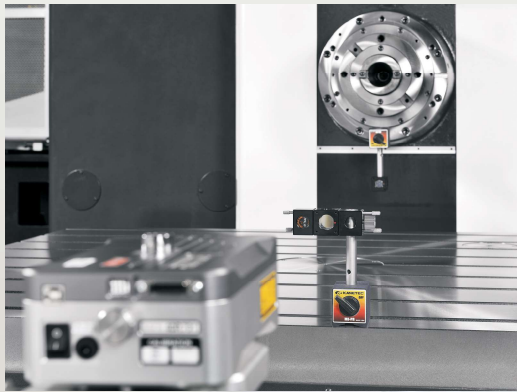

Laser Inspection Report

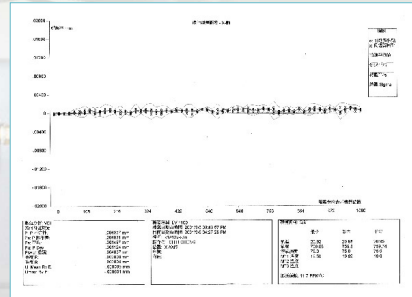

Full travel dynamic precision with laser compensation to ensure the best quality.

W Axis Precision Inspection

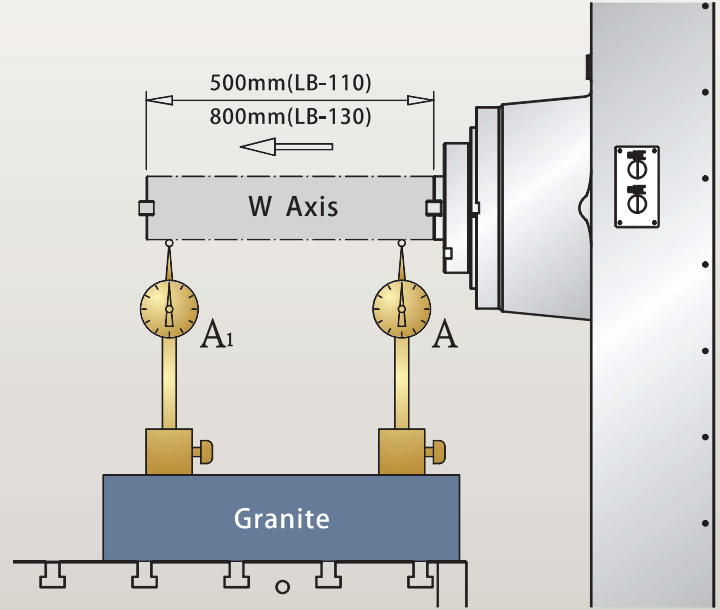

Ballbar Inspection

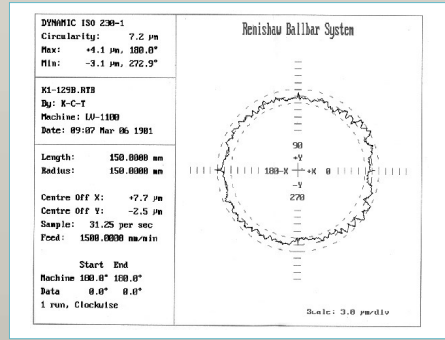
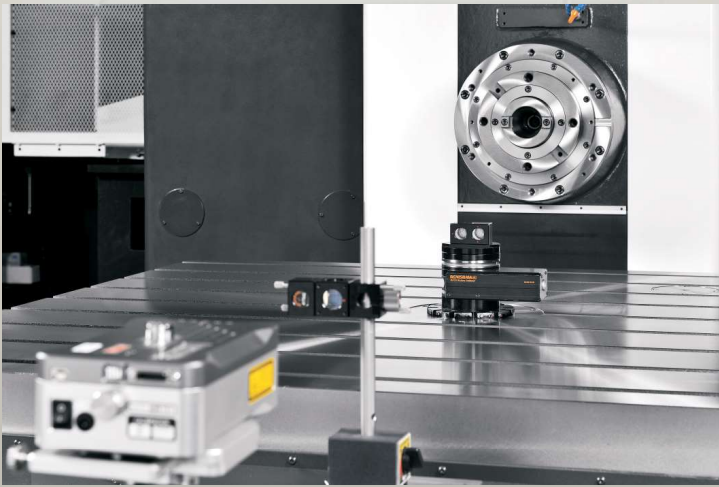

Ballbar inspection to ensure the dynamics the circular cutting.

Quality Regulation & Precision

Specimen Test Cut

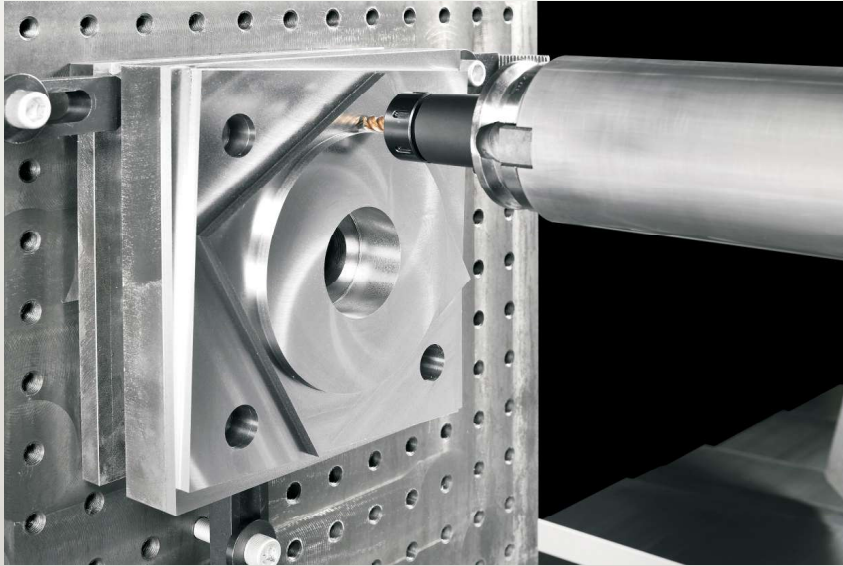

■ Prior to shipping, each machine must pass the test cut.

Carl Zeiss CMM Inspection



■ The test cut specimen are inspected through CMM equipment.

Specimen Precision Standard

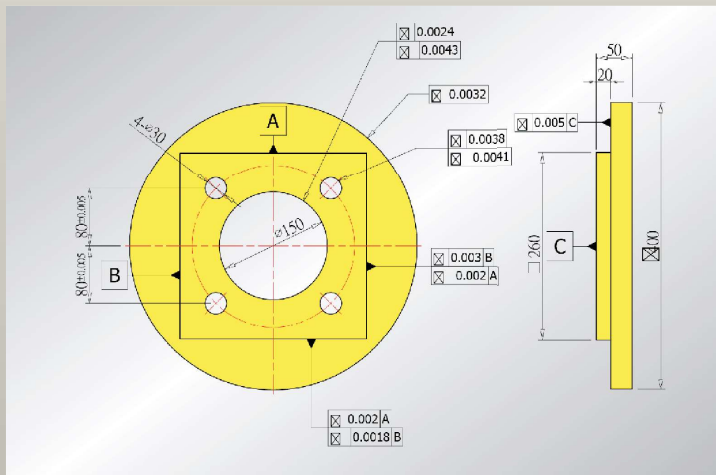

CMM Measurement Report



Cutting Test

Heavy Duty Cutting Test



- Each machine is assembled and tested with reliability test. Heavy duty test cuts are also performed. Precision check is then done to ensure the reliability of the machine.
- Apart from heavy duty test cut, grooving, maximum drilling and maximum tapping capabilities are also test.

Face Mill Cutting Range (Material #45 Medium Carbon Steel)

Tested Model		LB-110	LB-130
Face Mill Cutter	mm	Ø125	Ø160
Spindle Speed	rpm	477	170
Cutting Width	mm	100	160
Cutting Depth	mm	6	6
Cutting Feedrate	mm/min	1000	840
Spindle Power	kW	22	30
Material Removal Rate per Unit	cc/min.kW	27	30
Total Material Removal Rate	cc/min	600	800

Dual boring concentricity



Dual Bore Precision Requirement

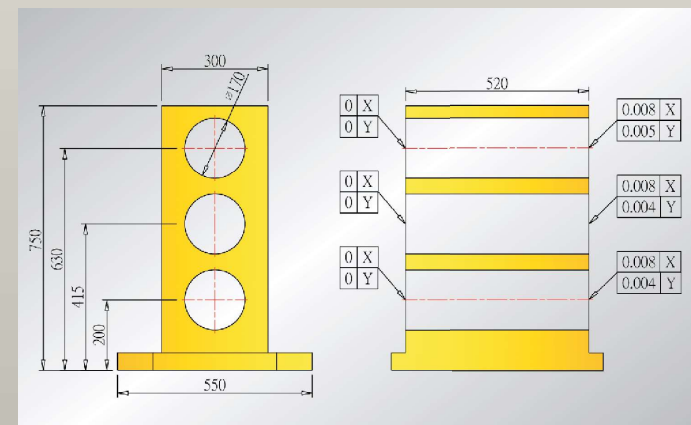

High Performance Options

Spindle Extension Sleeves



Work Light

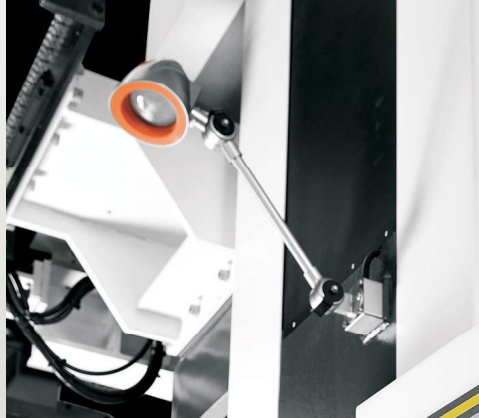

3 Axes Linear Scales

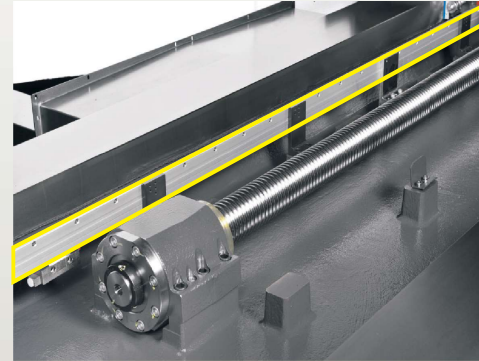

B Axis Linear Scales



Chip Conveyor

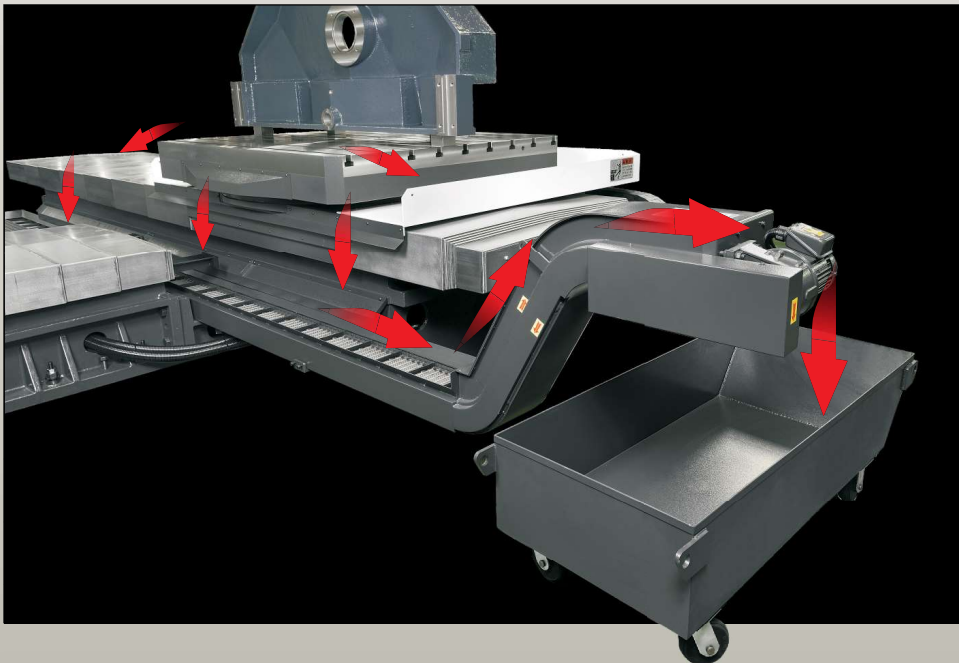

Spindle Oil Cooler



Air Conditioner for Cabinet



U Axis

LB-系列採用義大利D'ANDREA進口高性能高精度面盤，依工件大小，可選用 UT3-360S 或 UT5-630S 兩種型號。

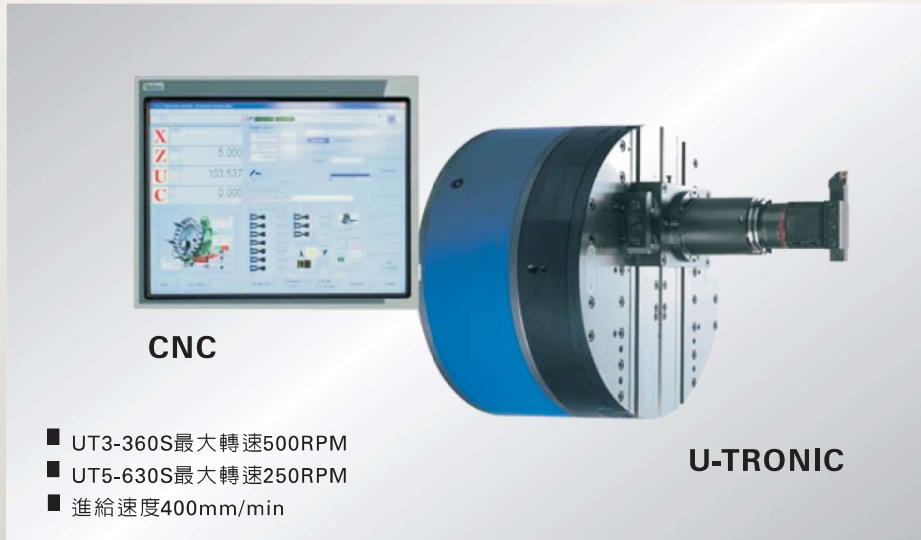

面盤內部結構圖

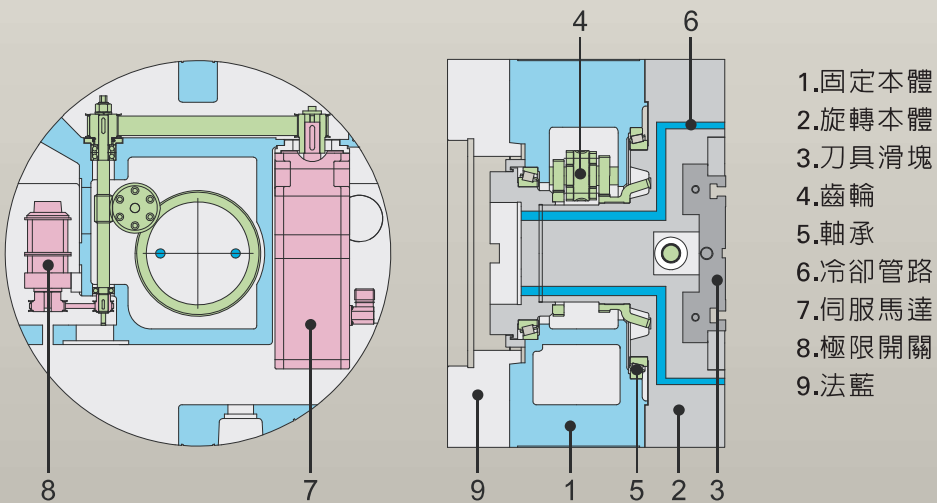

選擇配備

萬向銑頭 **OP**



CS45,CS50,CS60

直角工作台 **OP**



直角銑頭 **OP**



A75,N75,N76

45°角銑頭 **OP**



N45

註:另備有其他型式的銑頭，可供選用(請洽詢)

Foundation and footprint

Unit: mm

LB-110

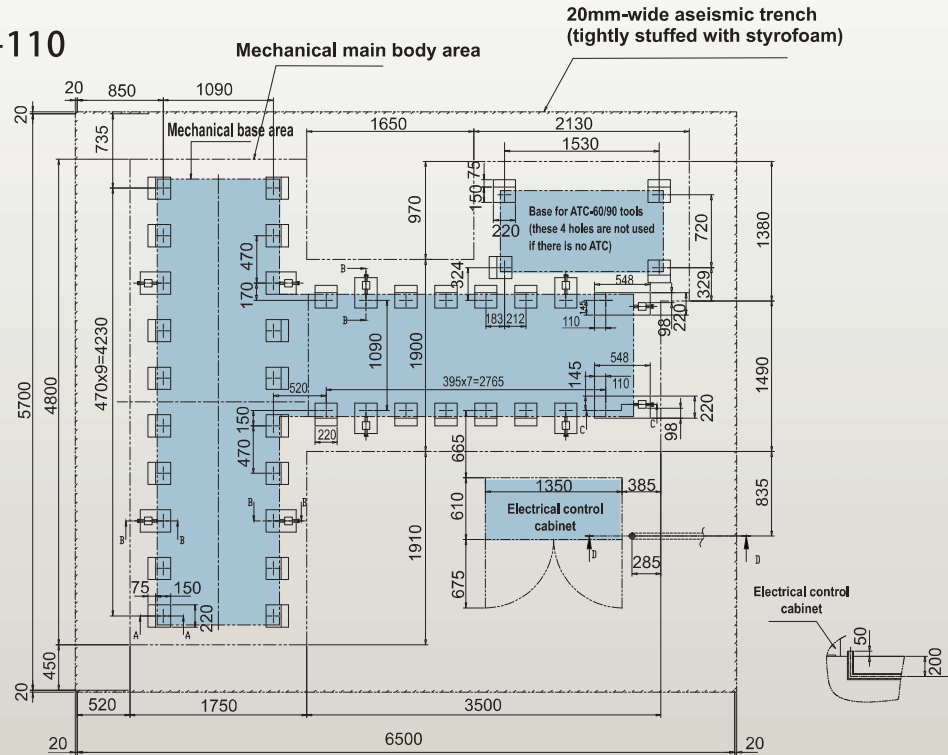

Note: use fast-setting and non-shrink cement to grout the foundation bolt pits

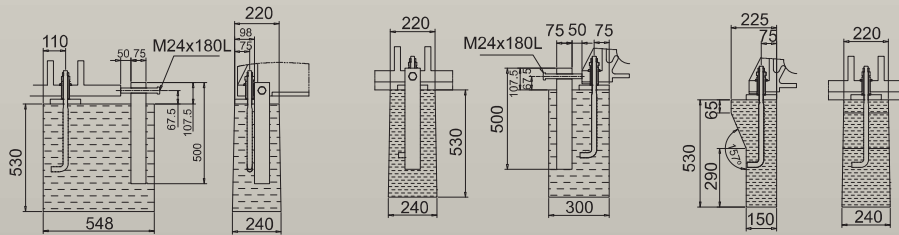
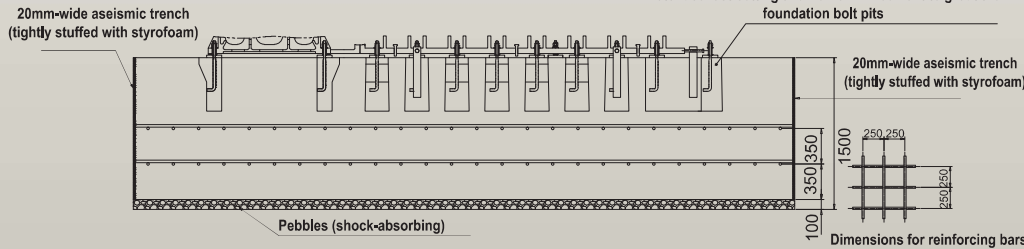

LB-130

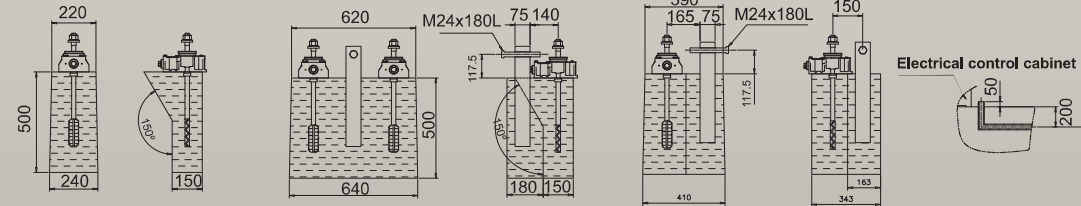
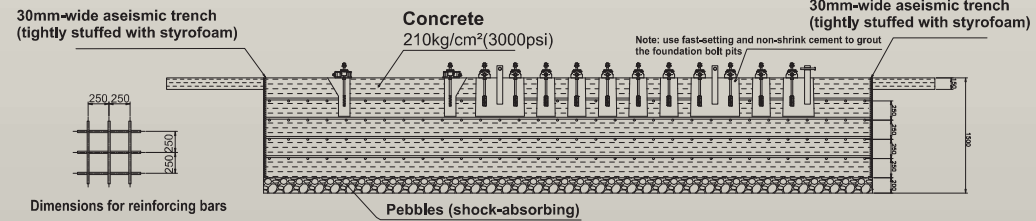
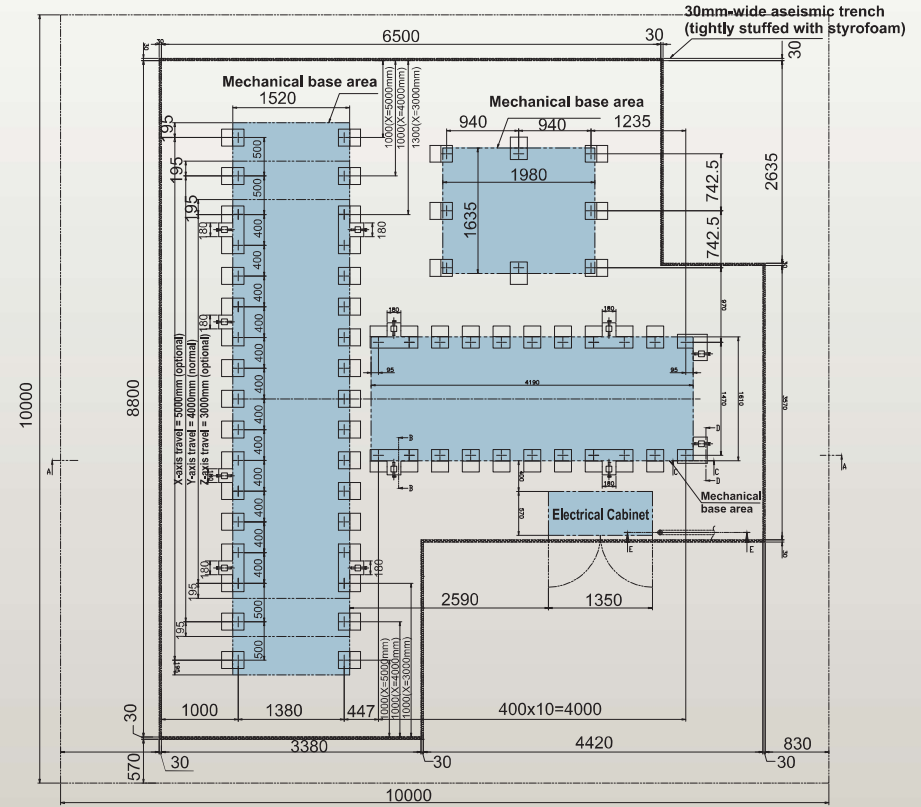

Machine dimensions LB-110

Unit: mm

Top View

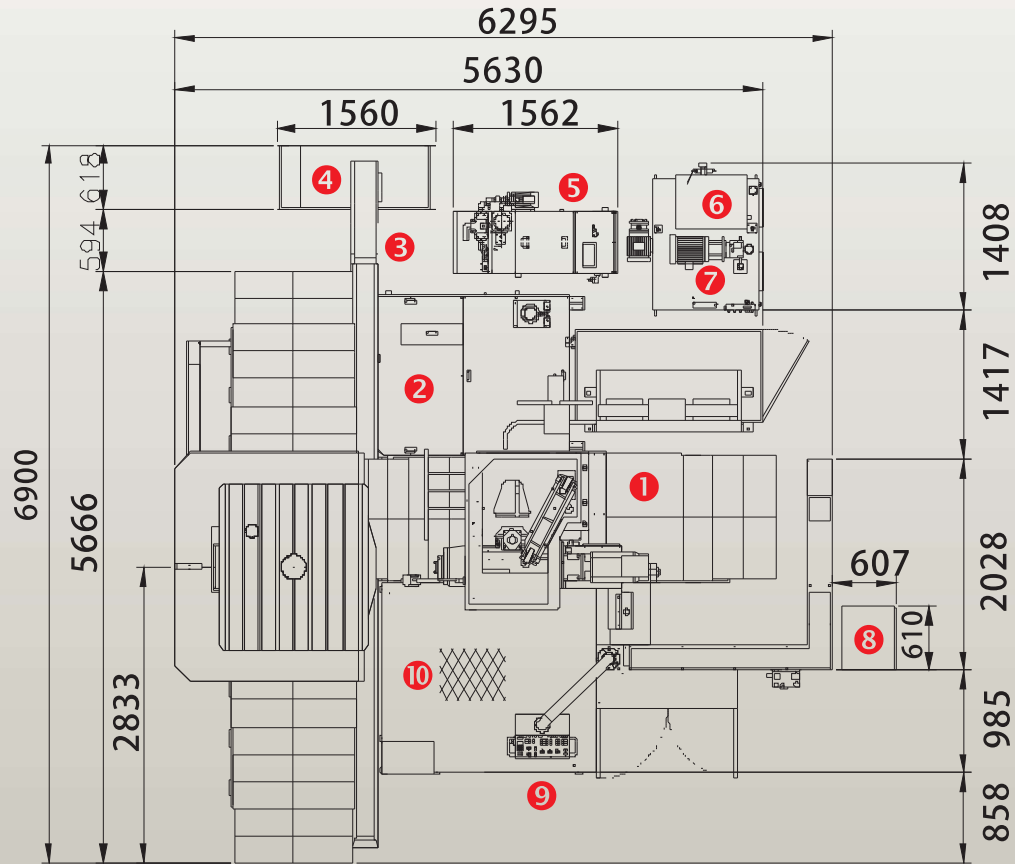

Side View

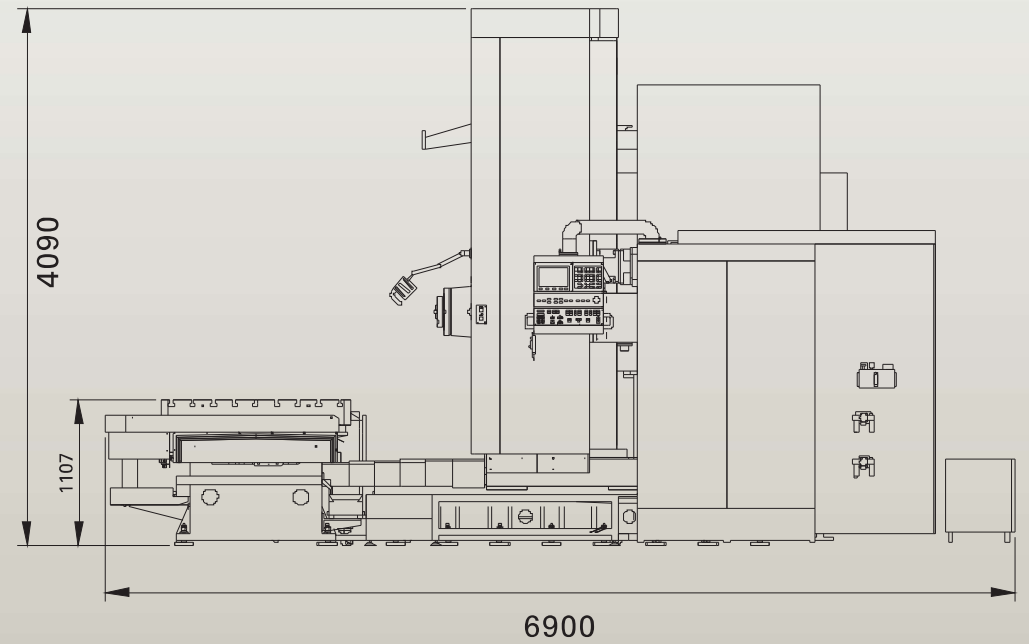

- | | |
|---|--|
| 1 LB-110 Main body | 6 Spindle Oil Cooling and Lubricating Unit |
| 2 Coolant Tank OP | 7 Oil Hydraulic Unit |
| 3 Chip Conveyor OP | 8 Transformer Unit OP |
| 4 Chip Cart | 9 Operation Console Unit |
| 5 Coolant Supply Unit for the spindle OP | 10 Foot Switch |

Machine dimensions LB-130

Unit: mm

Top View

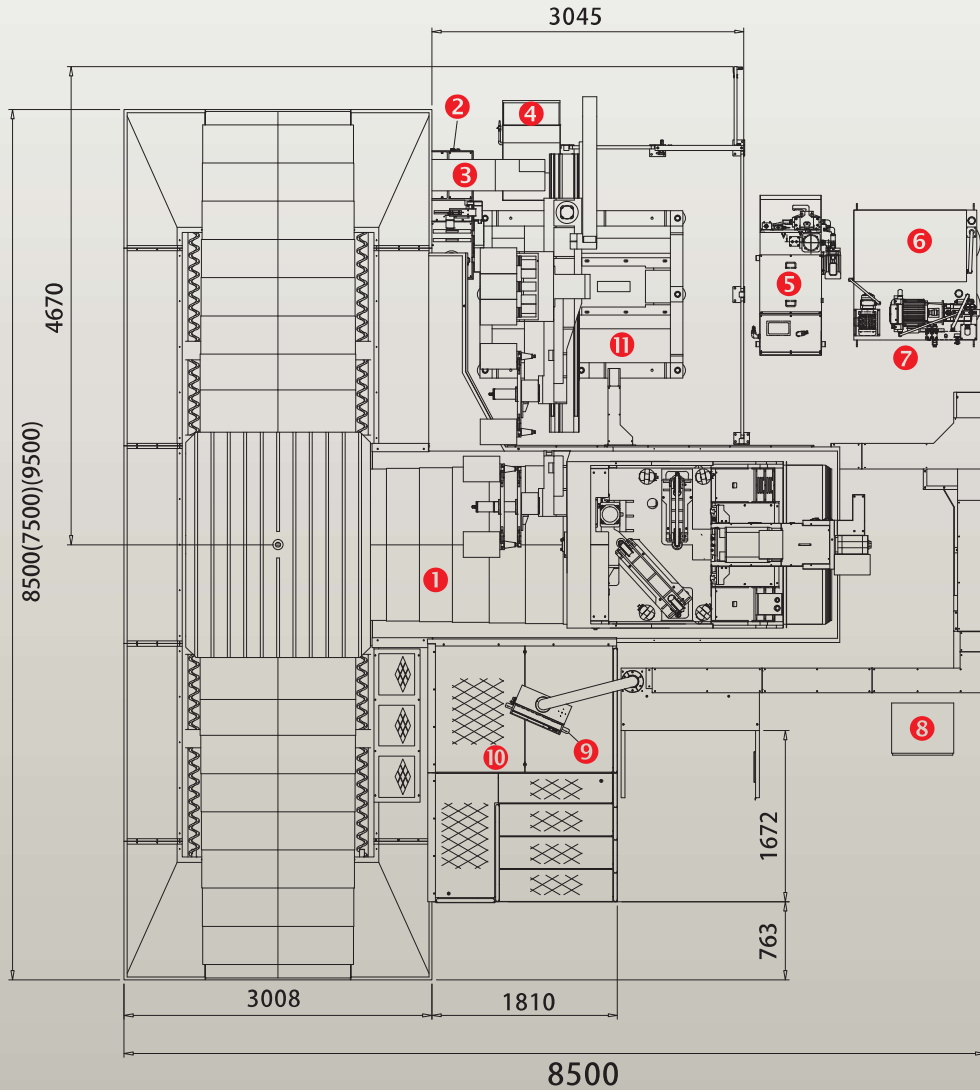

Side View

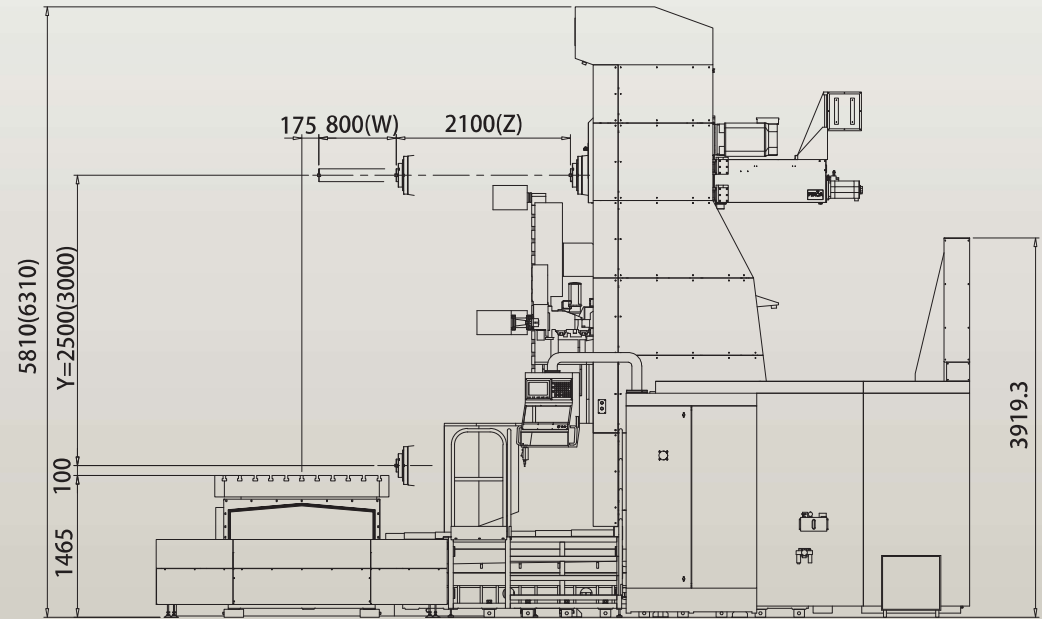

- | | |
|---|------------------------------|
| 1 LB-130 main body | 7 Oil Hydraulic Unit |
| 2 Coolant Tank | 8 Transformer Unit OP |
| 3 Chip Conveyor OP | 9 Operation Console Unit |
| 4 Chip Cart | 10 Foot Switch |
| 5 Coolant Supply Unit for the spindle OP | 11 Tool Magazine |
| 6 Spindle Oil Cooling and Lubricating Unit | |

Dimensions for Other Parts

Unit: mm

Worktable Dimensions

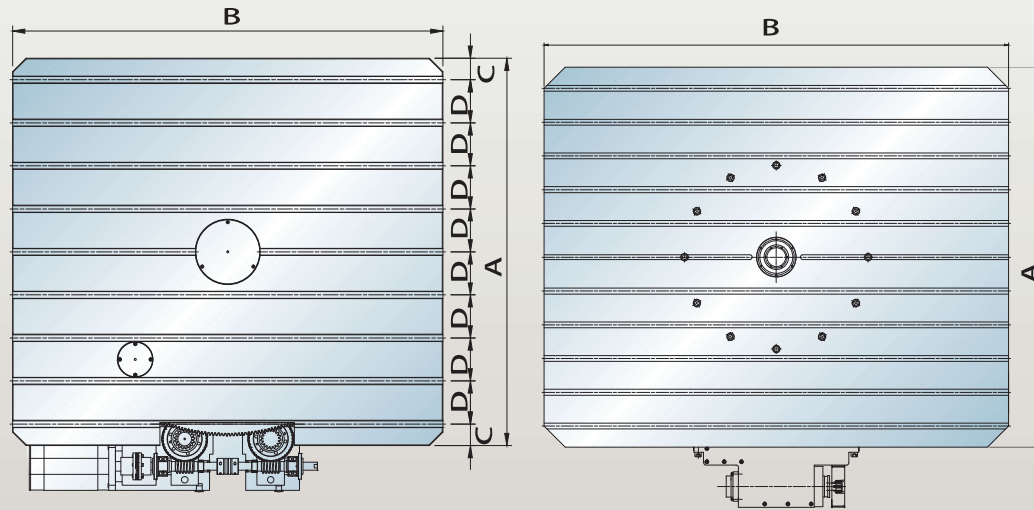

LB-110

LB-130

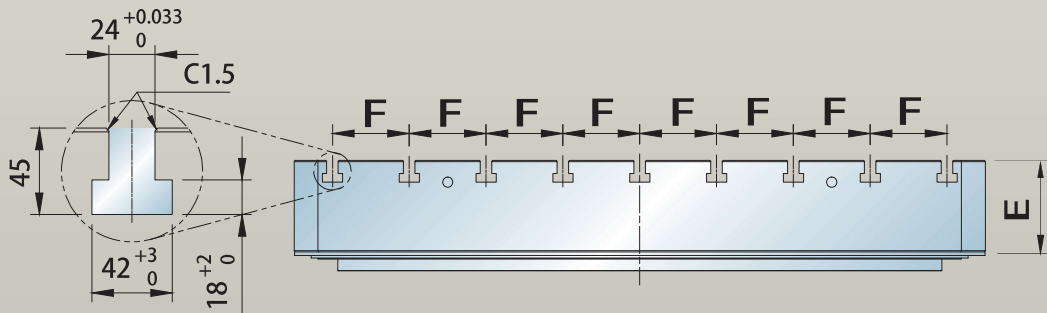

Part Model	A	B	C	D	E	F
LB-110	1400	1600	80	200	205	200
LB-130	1800	2200	100	160	220	160

Tool Shank and Pull Stud Dimensions (BT-50)

BT-50 Tool Shank Specifications

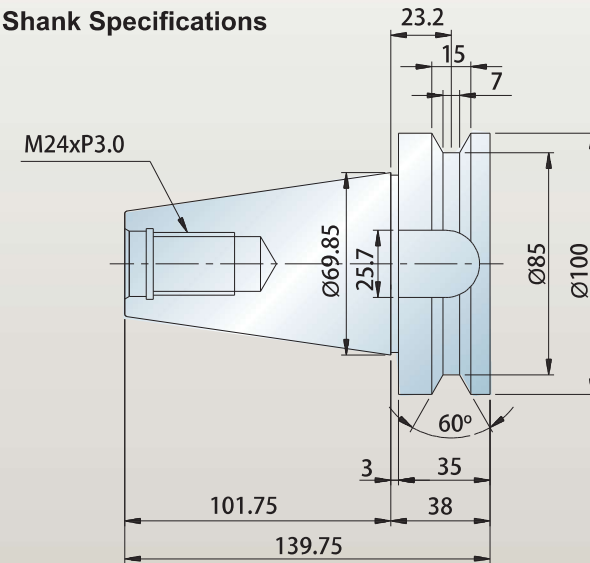

BT-50 Pull Stud Specifications

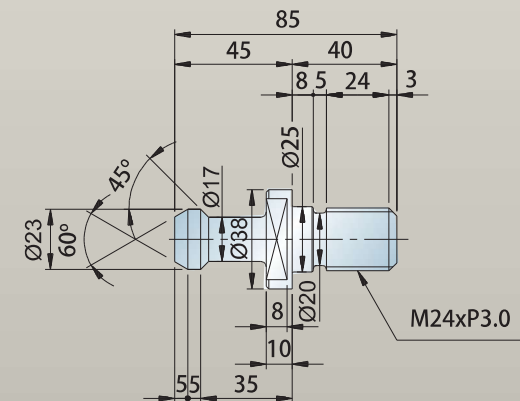

Technical Data

Machine Specifications

		LB-110	LB-130
Travel			
Worktable left/right travel (X-axis)	mm	3000	4000/(3000)/(5000)
Spindle up/down travel (Y-axis)	mm	2100	2500/(3000)
Column front/back travel (Z-axis)	mm	1500	2100
Spindle extension travel (W-axis)	mm	500	800
Spindle and head			
Spindle output power (continuous/30min)	kw	22/26	30/37
Spindle max. output torque	Nm	1274 / 1500	2000 / 2470
Spindle diameter	mm	110	130
Spindle Speed	rpm	2500	2500
Spindle taper	BT	No.50+MAS1	No.50+MAS1
Spindle lubrication		Oil lubrication	Oil lubrication
Spindle cooling system		Oil Cooler	Oil Cooler
Spindle Drawbar Force	kg	1800~2100	1800~2100
Worktable			
Worktable Dimensions	mm	1400x1600	1800x1800
Worktable T-slot	mm	24	22(24)
Worktable standard loading capacity	kg	8000	15000 for bearings (20,000 for hydrostatic) (8m/min)
Worktable positioning mandrel clamping force	kg	13500	13500(20000)
Worktable positioning resolution	Degree	0.001	0.001
Feeding system			
XYZ-axis rapid feeding	m/min	10	21
W-axis rapid feeding	m/min	4	4
Worktable max. speed	rpm	1	1(2)
Coolant			
Coolant tank capacity	L	500	500
Coolant pump motor power	kw	1.35	1.35
Hydraulic System			
Hydraulic system power	HP	10	10
Tool Magazine System			
ATC max. tool diameter	mm	120/250	120/250
ATC max. tool weight	kg	25	25
ATC tool changing time	sec	16	16
ATC Magazine station	pcs	60(90)(120)	60(90)(120)
ATC tool clamping force	kg	60+5	60+5
Installation Requirements			
Power Consumption	KVA	55	70
Minimum pneumatic pressure	kg/cm ²	6	6
Machine Outline Dimensions	mm	6900x6900x4100	8500x8500x5810
Machine Net Weight	kg	28000	56000
Machine Gross Weight	kg	30000	58000

■ All the photos contained herein are for reference only.
In case of any discrepancy with the actual machine parts,
the actual machine shall prevail. () refers to options.

■ LITZ reserves the right to modify the product specification,
appearance, equipment or discontinue the products.

Function List

	LB-110	LB-130
Spindle		
Spindle speed: 2500 RPM	●	●
Spindle oil cooling system	●	●
Coolant through spindle system	○	○
Cooling system		
Programmable air blowing system outside the spindle	○	○
Coolant cooling system	○	○
Chip Removal System		
Chip Conveyor	●	●
Chip Cart	●	●
Coolant gun for machine cleaning	○	○
Air gun for machine cleaning	●	●
Fully-covered sheet metal	○	○
Worktable Enclosure	○	○
Operation Cabinet	○ Fixed	○ Elevating Operation Cabinet
Measurement System		
Laser measurement for tool length	☆○	☆○
Workpiece Measurement	○	○
Worktable Unit		
Air/Oil source for jigs and fixtures of the worktable	☆○	☆○
Safety System		
CE Safety Regulations	○	○
Oil/coolant Separation System		
Disc type oil/coolant separator	○	○
ATC System		
Automatic Tool Changing Mechanism(Floor type)	●	●
BT-50 tool specification	●	●
60T Magazine station	●	●
90T Magazine station	○	○
3-Axis Transmission System		
3-axis BoxwayI (LB-110)	●	---
3-axis Boxway (LB-130)	---	●
3-axis linear scale	●	●
B-axis Rotary encoder	●	●
Y-axis hydraulic balancing system	●	●
Spindle extension sleeve 250mm (LB-110)	●	---
Spindle extension sleeve 400mm (LB-110)	○	---
Spindle extension sleeve 400mm (LB-130)	---	●
Electrical Components		
Working Light (LED)	●	●
Warning lights (LED)	●	●
M30 automatic power off function	●	●
Air-conditioner for electrical cabinet	●	●
Controller		
FANUC 0iMF	●	●
FANUC 31i	○	○
Siemens 828	○	○
Transformer Unit	☆○	☆○
Miscellaneous		
90° Milling Head	○	○
Universal Milling Head	○	○
90° Worktable	○	○
Rotary Face milling Heads (U-axis)	○	○

● Standard ○ Options ☆ Upon request

Total Production Solution

Highly efficient manufacturing fashion, equipped with high performance control system. The high speed contouring capability can achieve best possible surface quality under most demanding machining cycle time. Highly dynamic five axes machining provides solution for complex tasks.



Heidenhain & Siemens Control System

(TNC530 / 840D)
Ideal for high-end application CNC system. Modular, open, flexible operating interfaces are the highlight of the controller. Programming and visual structure can be integrated with network systems.



Litz Hitech & Open Mind, the CAM company
The strategic alliances



The monitoring & collision test within work range



MST Tools (Japan)

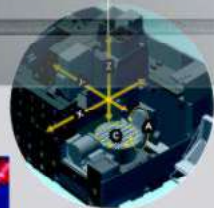

Litz Hitech LU Series

5 Axes Series employs U shape base with dual-support A/C axes rotary worktable's high rigidity mechanism. The machine is equipped with 12000RPM direct-drive high speed spindle. High durable roller type linear guideways, 3 axes high precision linear scales along with other high quality components brings out the excellences of the 5 axes simultaneous control. Mill, drill, tap, spiral, irregular and other complex machining can be easily achieved.

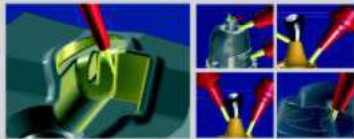

Technical Support Global Presence



SALES & DISTRIBUTION NETWORK



www.litzhitech.com

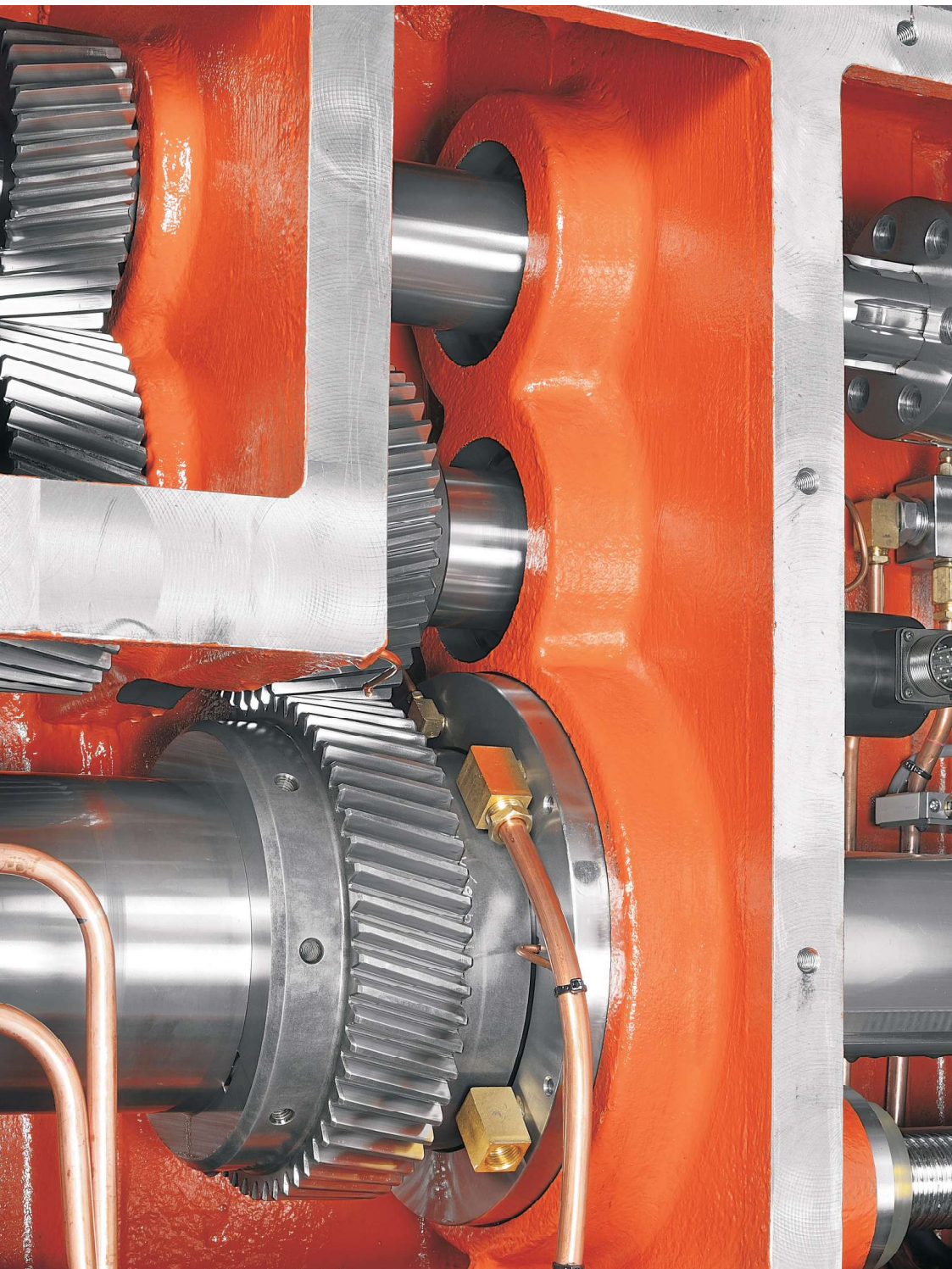

Dealer

Manufacturer



Litz Hitech Corp.

No. 18, Yu 9 Road, Yu-Shih Industrial Park,
Tachia District, Taichung City, Taiwan
TEL: +886-4-26815711
FAX: +886-4-26815108
E-mail: sales@litzhitech.com
<http://www.litzhitech.com>



Litz Machine Tools (JiaXing) Corp.

No. 1398 Hefeng Road, Jiaxing, Zhejiang
TEL: +86-573-82222735
FAX: +86-573-82222739
E-mail: sales.jl@litzhitech.com
<http://www.litzchina.cn>



Welcome to Litz website for more information