



**LITZ**

熱情領導 · 創新科技

# LU

Series

800

1200



5-AXIS MACHINING CENTER

5-Axis Integrated Machining Solution

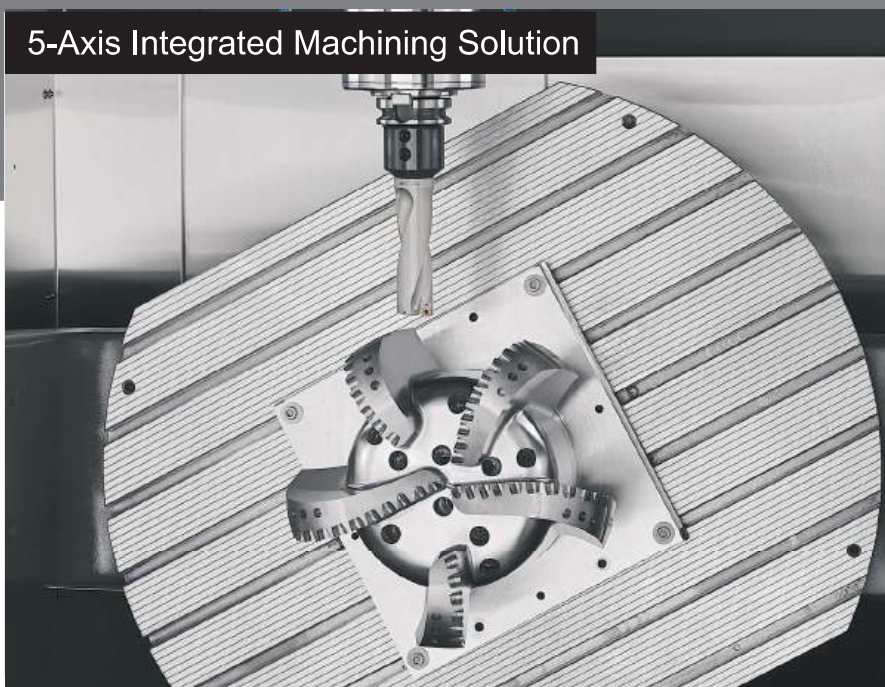

LITZHTECHCORP.  
LITZPrecision Machinery(Jiaxing)Co.,Ltd.

# Table of Contents

## Overview

- 01 - 02 Cover Page/Index
- 03 Technical Features
- 04 - 05 Machining
- 06 - 07 Integration

## Structure

- 08 Dynamic Performance
- 09 Dual-Motor Driving
- 10 Spindle
- 11 Transmission System
- 12 - 13 Rotary Axis (A-Axis, C-Axis)
- 14 ATC and Magazine Unit

## Chip Conveying System

- 15 Chip Management
- 16 Coolant System

## User-Friendly Operation and System

- 17 User-Friendly Operation
- 18 Controller
- 19 - 20 High Performance Configuration
- 21 Accessibility
- 22 Maintenance Servicing

## Measuring/Accuracy

- 23 Online Measuring
- 24 Machining Test
- 25 CAM Software

## Working Table

- 26 Machining Demonstration
- 27 Working Bench

## Outline Dimensions

- 28 - 33 Outline Dimensions
- 34 Technical Information

## Sales Service

- 35 Sales Service Information



# Content

## ATC Unit



## Machining Application



## Maintenance Servicing



## Transmission System



## DCM Anti-Collision



## Structure



## TCP Calibration



## Measuring System



## Structure

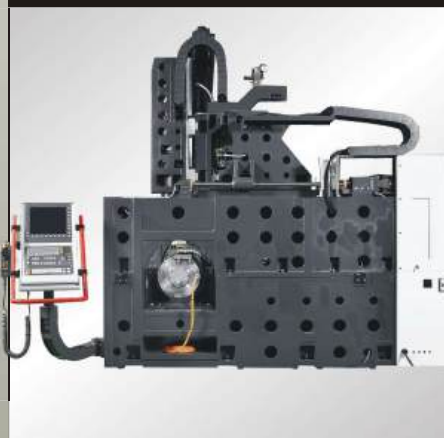

## Spindle System



## Controller System



## A / C Axis



## Thermal displacement control



## Chip Conveying System



## Technical Features

### Excellent Stability and Rigidity

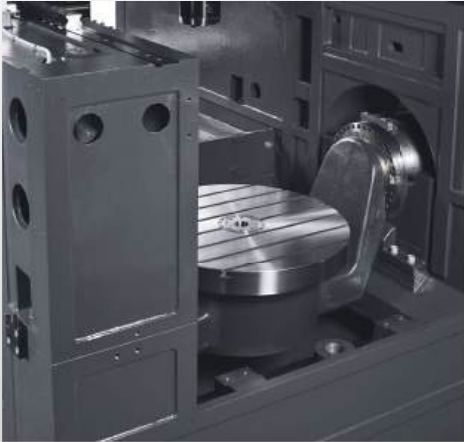

- Preconditions for excellent accuracy and optimal Workpiece surface quality: Excellent machine rigidity and satisfactory stability of parts.

### Ergonomics



- The operation door can be opened to the maximum level for the user to freely access the working area. With large-size glass window, it allows the user to clearly observe the entire machining process. LITZ LU is designed to realize superb accessibility.
- The Working Bench, Magazine and Chip Conveying System allow easier accessibility and operation.
- The Working Bench can be loaded and unloaded with crane. Further, it is also provided with movable ceiling.

### Superb Accessibility

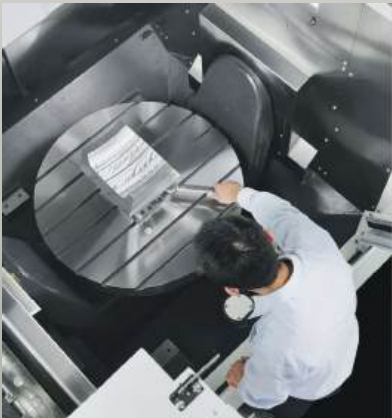

- Superb flexibility and accessibility are the unique features highly regarded by users. Smaller Workpiece can be easily loaded and unloaded manually on the fully interactive rotary-oscillating Working Bench.

### Excellent Chip Management



- It provides proper treatment of the chips produced in working area. Chips guided by perfect structural angle and flowing toward to chip conveyor.

## Smart Control System

### Heidenhain Digital Control System **OP**

#### Heidenhain TNC-640

- With the new generation Heidenhain TNC-640 Digital Control System and clearly defined operation panel, the LU Series is now a safe working center convenient for operation.
- High-quality stainless steel operation panel.
- Bright LED clearly displays the function of machine during the operation.
- Integrated Kinematics Opt allows automatic measuring and calibrating the accuracy of the rotary axis.
- It provides the integrated 5-Axis interaction to achieve highly efficient cutting performance.
- Dynamic Collision Monitoring function can immediately prevent the potential collision that may occur to all components in the working space.
- Intelligent adaptive control function to present optimized cutting accuracy, surface quality and efficiency.



### Siemens Digital Control System **OP**



#### SINUMERIK 840D si

- The CNC System suitable for high-level application solution.
- It provides modularized, open, flexible structure and consistent operation interface as well as program writing and visualized structure. Further, it can also be integrated on the network with the optimal method.
- It integrates the high power density in the modularized SINAMICS S120 Drive System.

## High-precision 5-Axis Machining

LU series is designed for highly efficient production mind set. It is equipped with high-performance control system to execute high-speed contour control for achieving the optimal surface precision within the shortest machining time accuracy with the shortest working time. Driven by highly dynamic 5-axis, it can provide machining the highly complicated Workpiece to satisfy the requirements for 5-Axis machining.

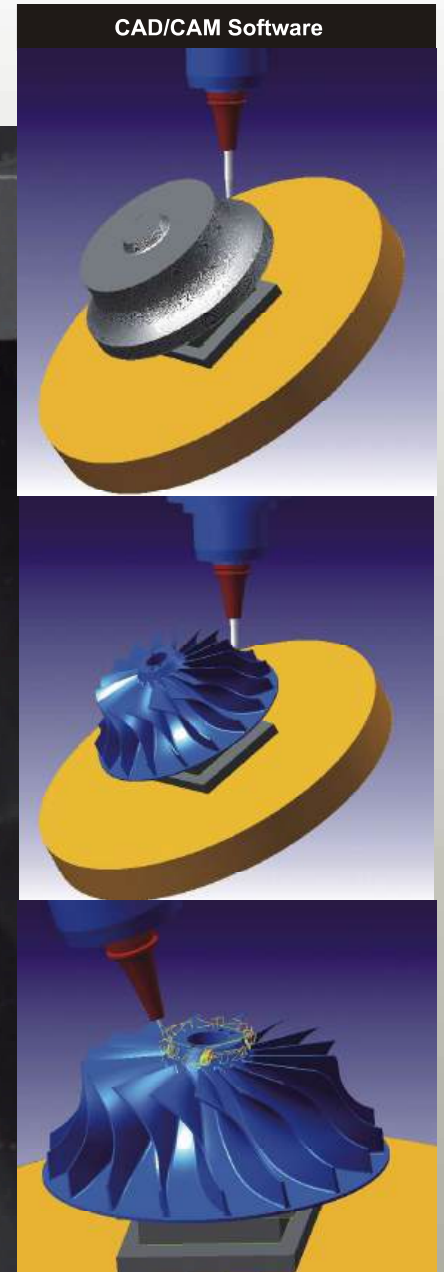

## LU Series - Vertical Machining Center (5-Axis)

LU series enters new era for 5 axis. LU series perfectly achieving technical accuracy, high efficiency and modern control system Besides. LU series is with the best cost-performance ratio.

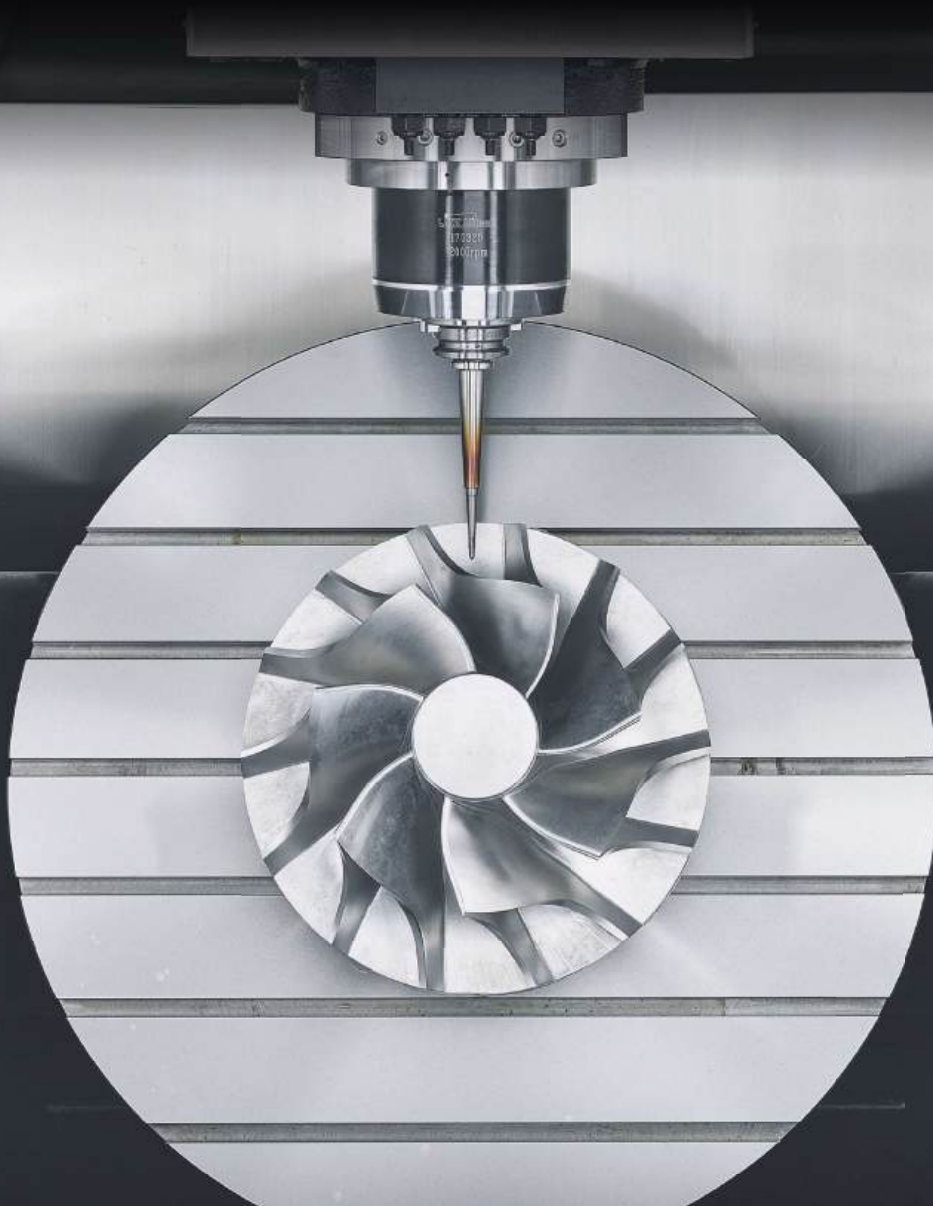

## Crane-type High-Level 5-Axis Machining Center

The most advanced Direct drive Spindle can handle the high-speed Tool to carry out economical and accurate machining by directly drive the Rotary C-Axis and tilt A-Axis.



## Newest High-Level 5-Axis Machine (LU-800A/B)

LU Series Crane-type 5-Axis Machining Center is configured in high-rigidity structure where the U-shape base and dual-side supported A/C-axis rotary table are installed. In the meantime, it is also equipped with high-quality components such as standard high-speed direct-driven Spindle, heavy-duty roller linear slide rail and 3-axis precision optical scale for achieve 5-axis high-accuracy interactive control through X, Y, Z, A and C axes. In this way, it can easily complete the complicated machining tasks such as milling, drilling, tapping, tapering, spiral curve machining, and irregular curve machining, etc.

### Features

- Robust gantry structure.
- High-rigid crane design
- Y-Axis is fitted with heavy-duty servo + dual ballscrew driving
- Y-Axis synchronous precision mass center for fast moving
- High-torque, high-precision A, C-axis rotary table
- Optimal drainage and chip removing
- Max. machining envelop
- Min. floor plan area



(LU-800A/B)

## High-performance 5-Axis Machining Center (LU-1200B)

- Through the interaction of 5 axes, it is used to execute the machining of complicate-shape Workpiece. Further, it is also featured on one-process clamping for multi-face machining.
- The new-generation high-efficiency production achieved through the conglomeration of high-quality machining and working sequence.
- Perfect integral configuration by combining man and machine in creating comfortable operation environment and operation space.



(LU-1200B)

New level of Kinematics

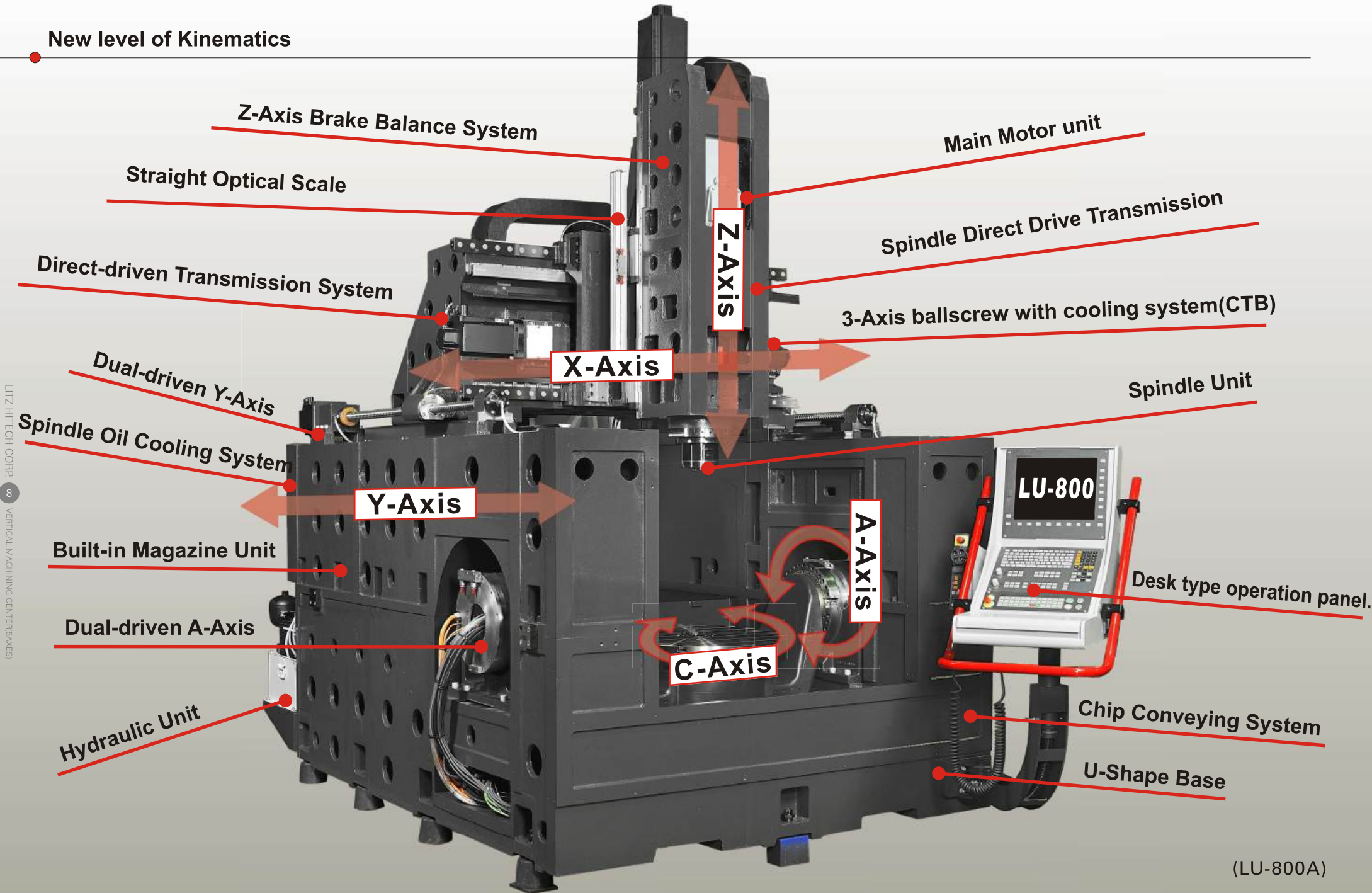

Z-Axis Brake Balance System

Main Motor unit

Straight Optical Scale

Spindle Direct Drive Transmission

Direct-driven Transmission System

3-Axis ballscrew with cooling system(CTB)

X-Axis

Spindle Unit

Dual-driven Y-Axis

Spindle Oil Cooling System

Y-Axis

A-Axis

Built-in Magazine Unit

Desk type operation panel.

Dual-driven A-Axis

C-Axis

Hydraulic Unit

Chip Conveying System

U-Shape Base

LU-800

(LU-800A)



# Excellent Performance of Heavy-duty Dual-Motor

## Dual-Servo Interactive Control Technology

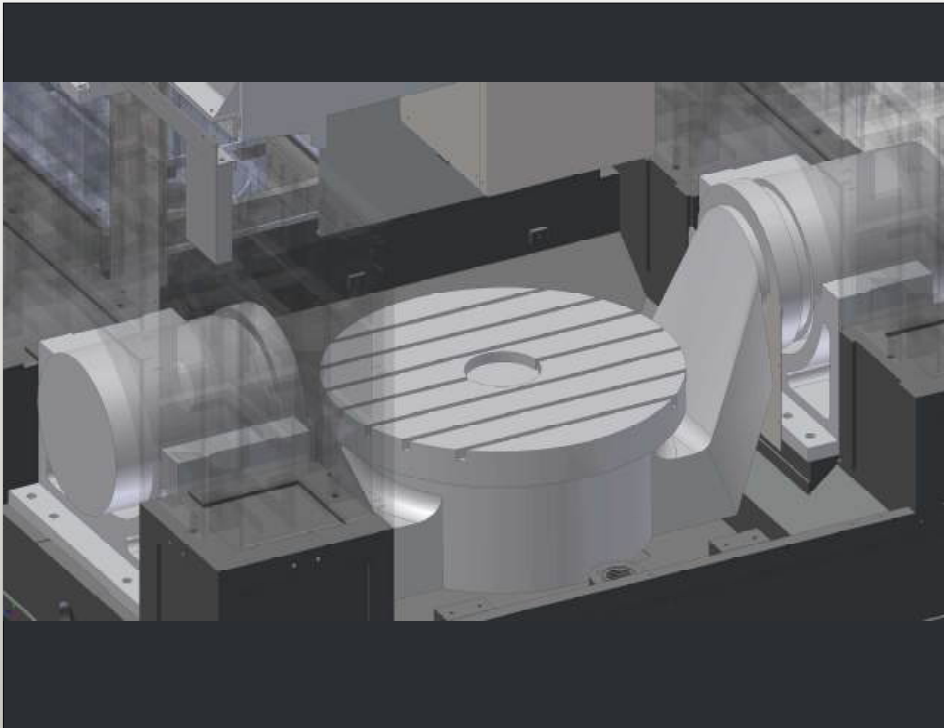

- Fast cutting task can be achieved through strong power of dual-motor configuration.
- With excellent synchronization feature of Y-Axis, Y-Axis and V-Axis can activate the Servo synchronously within 5u.
- Ensure min. rotating oscillating error when the horizontal beam is moving.
- Fixed kinematic mass of X, Y and Z axes, it provides safe machining parameters.
- Machining efficiency can be enhanced by upgrading upgrading Axial feeding and working speed.
- During the machining process, 5 axes are continuously rotating to easily removing the chips and coolant.
- It provides double-layer effect of fast cutting and precise alignment.

## Y-Axis Dual-Servo Synchronous Control Technology

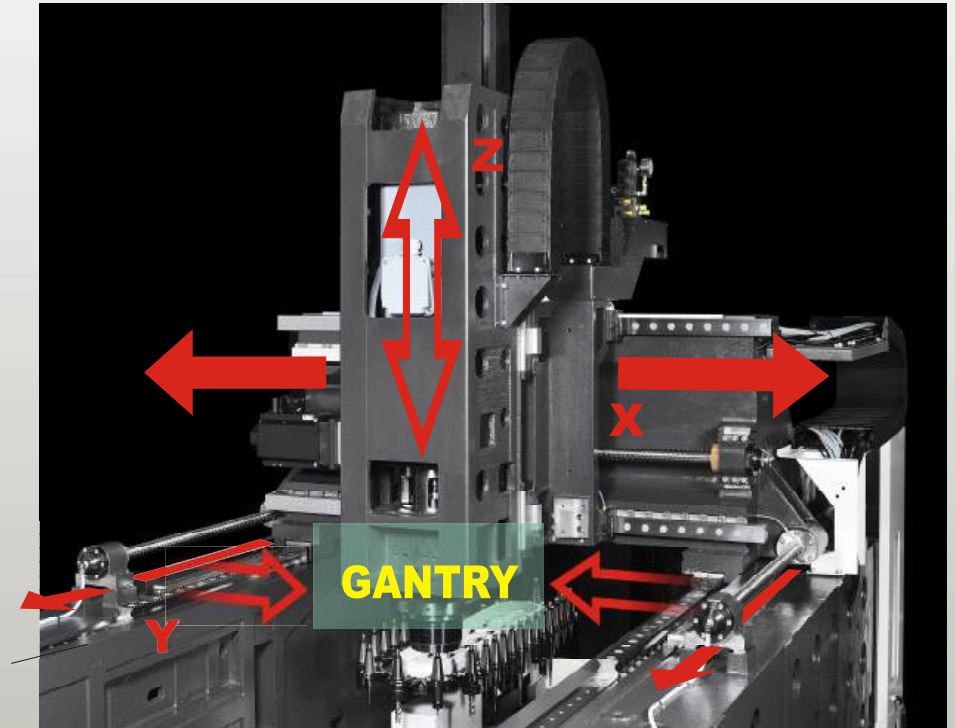

By configuring the horizontal beam and saddle Spindle Head at the upper part of Gantry Sliding Rail, they can be activated by powerful dual-motor like crane and such unique design has the following excellent performance:

### Y-Axis Dual-Servo Synchronous Control Technology

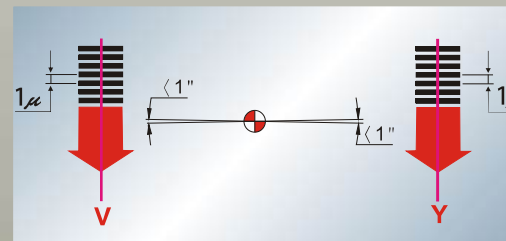

### Synchronous Control Accuracy

Y-Axis Dual-ballscrew(Y and V), with synchronous feeding coordinates.

X	+0.000
Y	-600.000
Z	+0.000
A	+0.000
C	+0.000

# Spindle Unit (S-Axis)

## Spindle

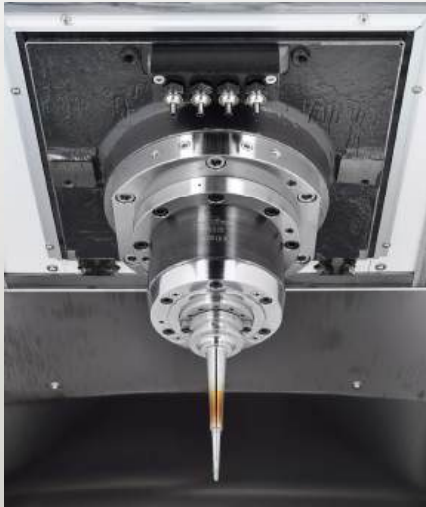

- The LU Series Tools are specially designed for realizing the high-performance machining. Even under high-speed condition, it can still achieve higher performance and bigger torque.
- Accuracy and highly efficiency, suitable for high-performance cutting application.
- Operating through the Spindle Center Cooling system.
- With the Oil Cooling Unit fitted in the Spindle, it ensures the stability in temperature and Spindle action.
- Such feature provides extremely accurate machining effect, because it has minimized the heat impact to the Spindle.

# High Tech Spindle

## Spindle and spindle motor unit

- Advanced Spindle technology can ensure a total-torque output within the low-speed range. Highly stabilized composite ceramic Spindle bearing. Further, the Spindle Housing is fitted with constant-temperature cooling unit to maintain the Spindle at fixed temperature during the entire operation process.
- The latest design of Direct Drive Spindle can output bigger cutting torque, thus removing massive amount of chips. Such type of Direct Drive Spindle is also convenient to maintenance structure.
- Built-in spindle with high-speed torque output can be selected.

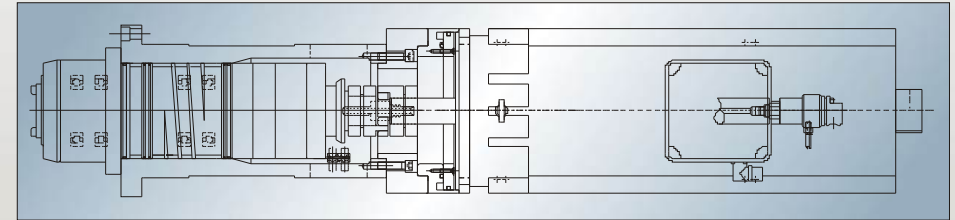

**Direct Drive Spindle (standard) (LU-800A)**

**Spindle speed: 12000rpm**

**Spindle taper: BBT-40**

**Direct Drive Spindle (standard) (LU-800B/LU-1200B)**

**Spindle speed: 8000rpm**

**Spindle taper: BBT-50**

## Spindle Motor Torque Curve (LU-800A)

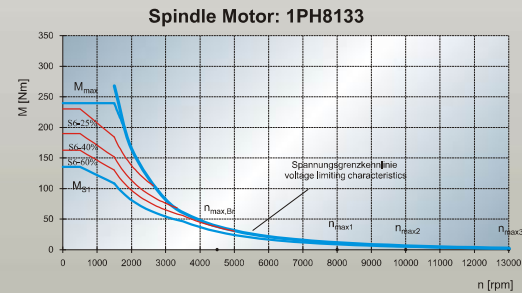

## Spindle Motor Torque Curve (LU-1200B)

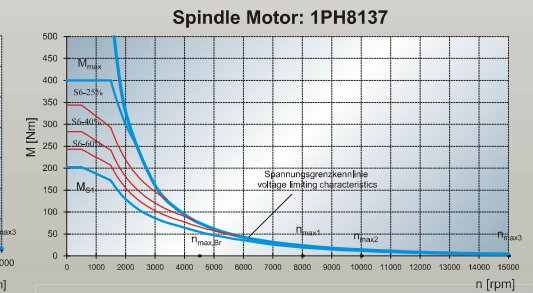

## Spindle Motor Torque Curve (LU-800B)

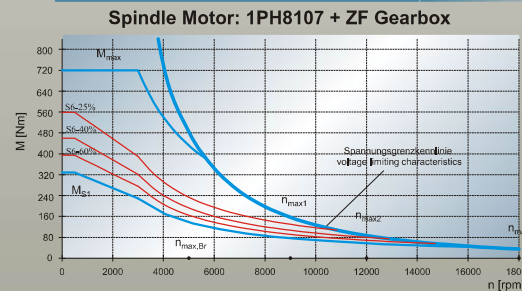

## Spindle Direct Drive

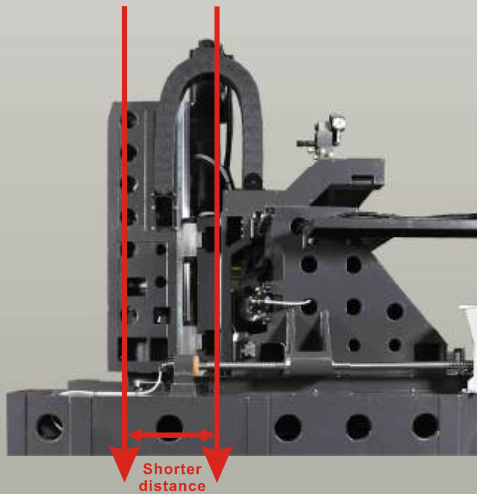

### IDD (Isolated Direct Drive System) is the optimal heat-isolating design

- The heat-isolation is the direct drive design for the Spindle. In this way, it reduces the thermal displacement and enhances the accuracy and lifespan of the Spindle.
- The Heat-isolating Shaft Coupler is designed between the Motor and the Spindle. The oil cooling control can be selected for the entire Spindle to achieve higher level of accuracy control.
- The Spindle is directly driven by the Motor to avoid the noise, backlash and vibration problem during the transmission process of the belt or the gear.
- Because the Spindle is directly driven by the Motor, it enhances the motor efficiency and the speed can be directly detected from the Motor to achieve higher quality of rigid tapping.

- Extremely short Spindle suspending length can prevent Spindle Head from deformation of overhanging; thus, ensuring the rigidity and accuracy during the cutting.



# High Precision Transmission System (X, Y, Z axes / A, C axes)

## Direct Drive Axis (X, Y, Z axes)

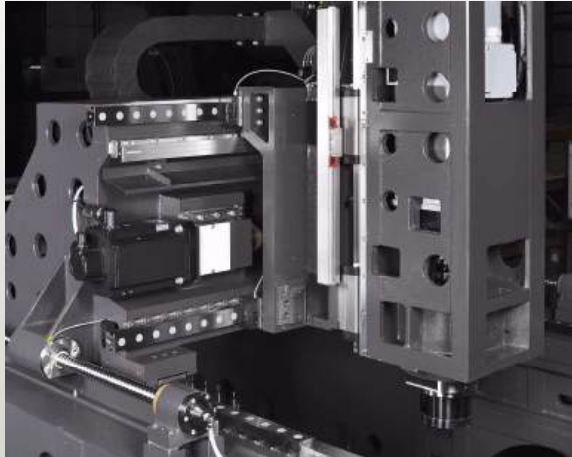

- During high level of machining production, the linear technology can settled enhance the machining efficiency and accuracy. With the stabilized structure, a new standard has been created by this model. By technological component, it achieves higher cutting speed while presenting the optimal repetition accuracy and dynamic performance.

## X, Y, Z axes equipped with optical scale

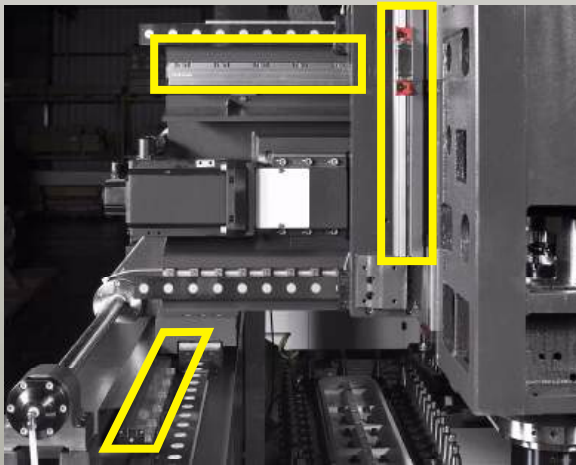

- The X, Y and Z axes can install Optical Scale System to detect the thermal displacement due to the fast moving of the machine and transmit back such thermal displacement to the Controller to execute compensation. It is suitable for the high-precision parts machining.
- The Optical Scale System is provided with gas protection device to prevent the Optical Scale from contamination by dust and oil mist. It can ensure the accuracy of Optical Scale and prolong optical scale's lifespan.

## Rotary Axis (A, C axes)

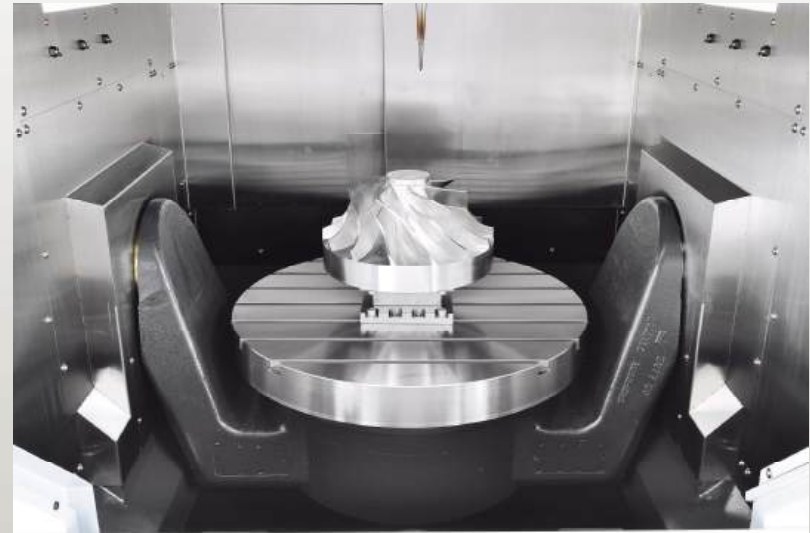

## A, C Axes Optical Scale



## High-torque / High-accuracy Rotary table (A, C axes)

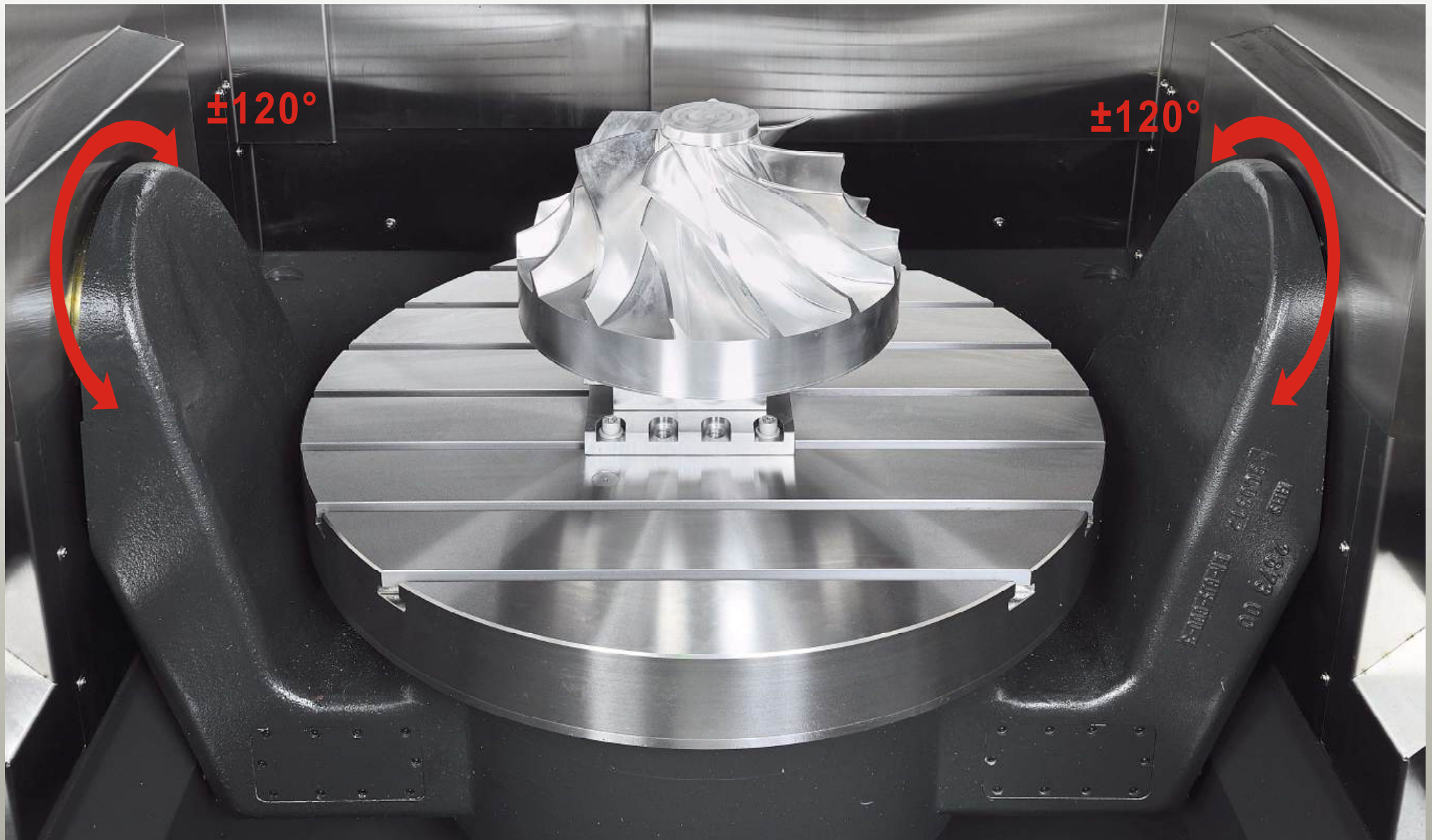

## A, C Axes (Rotary Axes) Unit

A, C axes are using Direct Drive Motor to work with the Rotary Table detected by encoder. Its performance is far superior in power transmission efficiency and the reduction of power consumption than the conventional gear structure.

- Higher freedom in the working area
- Working Bench load:  
(LU-800A/B max. load: Up to 1000 kg)  
(LU-1200A/B max. load: Up to 2000 kg)

- Table is free of chip piling
- The tilting A-Axis and the Rotary C-Axis are in the Workpiece center(U-shape).
- Prevent the Twisted deformation by dual-drive calibration function.

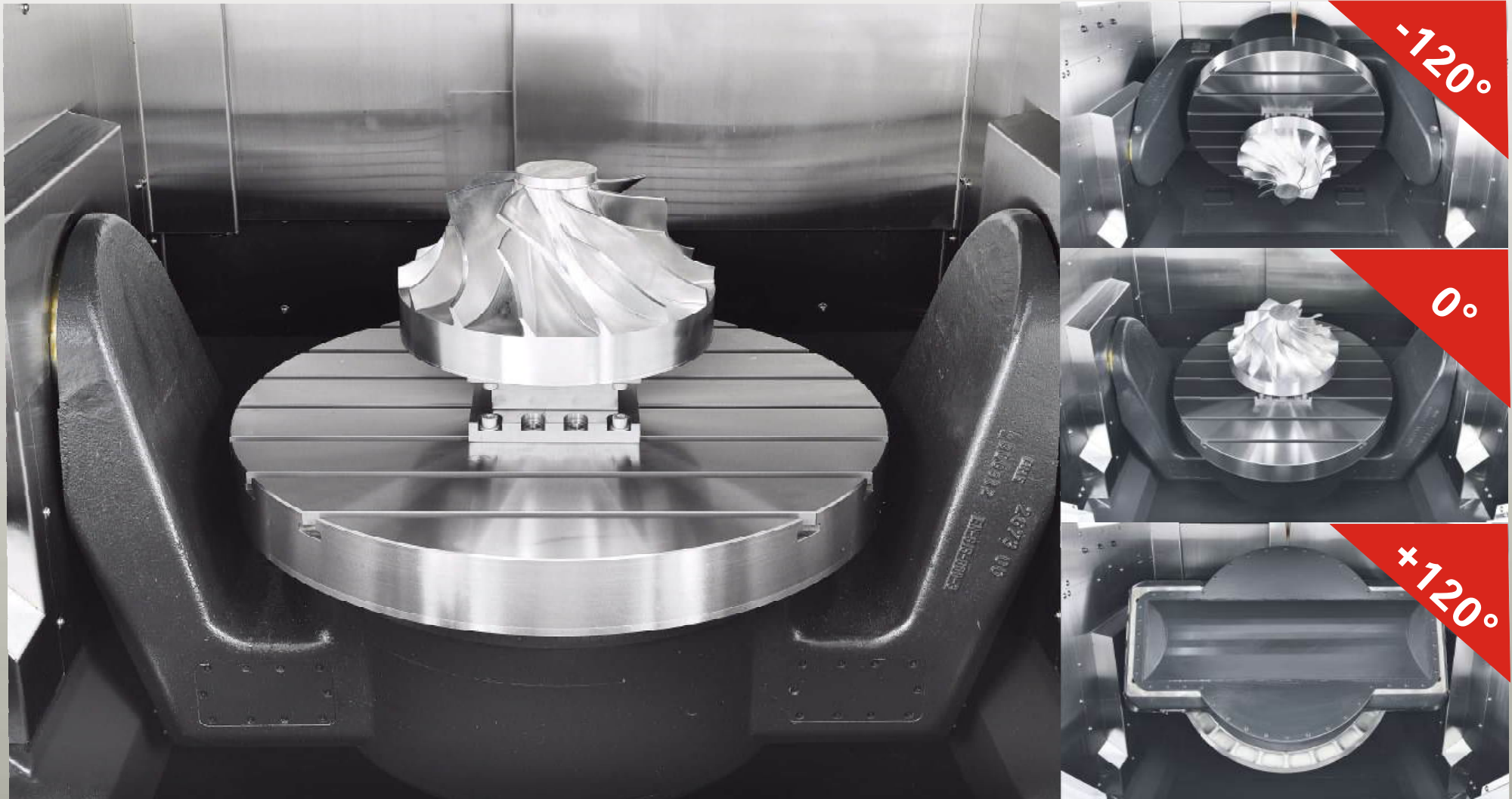

# ATC and Tool Magazine



■ The Dual-Magazine Unit is designed for option by the customer according to different workpiece and demand for the number of Tools.

## Tool Magazine Unit

**LU-800A**  
 Magazine capacity: 32T  
 Max. Tool Length: 300 mm  
 Max. Tool Dia.: 75 mm  
 Max. Tool Weight: 7KG  
 Max. Magazine Load: 128KG

**LU-800B**  
 Magazine capacity: 24T  
 Max. Tool Length: 300 mm  
 Max. Tool Dia.: 125 mm  
 Max. Tool Weight: 15KG  
 Max. Magazine Load: 240KG

**LU-1200B**  
 Magazine capacity: 24T  
 Max. Tool Length: 400 mm  
 Max. Tool Dia.: 125 mm  
 Max. Tool Weight: 15KG  
 Max. Magazine Load: 240KG

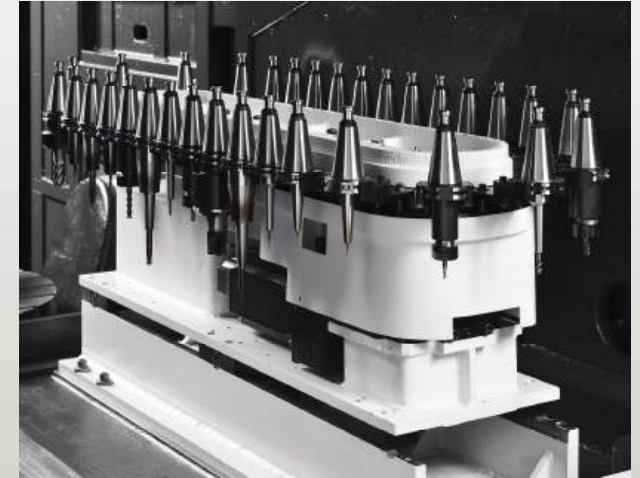

## Model with A, B Tool Magazine Unit

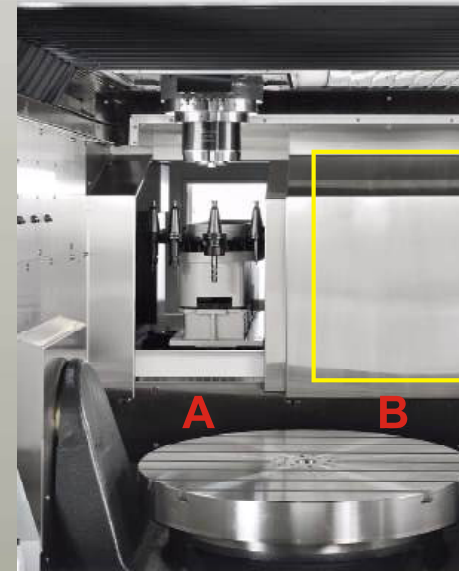

**LU-800A**  
 ■ Magazine-A Unit  
 Magazine capacity: 32T (standard)  
 ■ Magazine-B Unit  
 Magazine capacity: 32T (option)

**LU-800B**  
 ■ Magazine capacity: 32T (standard)

**LU-1200B**  
 ■ Magazine-A Unit  
 Magazine capacity: 24T (standard)  
 ■ Magazine-B Unit  
 Magazine capacity: 24T (option)

# Chip Management

## Chip Space and Chip Management

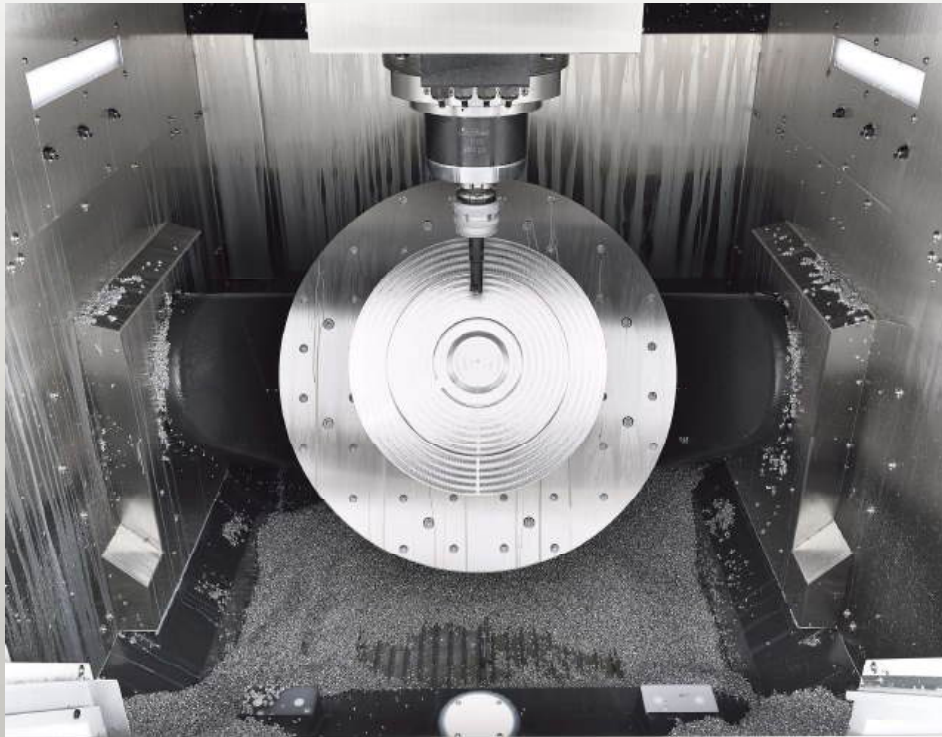

It can effectively remove the chip out of the steep smooth stainless steel inner wall. In this way, the Chip Conveying System can effectively prevent the chips from gathering.

## Practical Chip Trolley



## Shaft-type Chip Guard



## Crawler-type Chip Conveying System

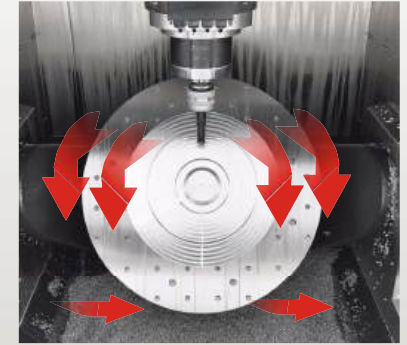
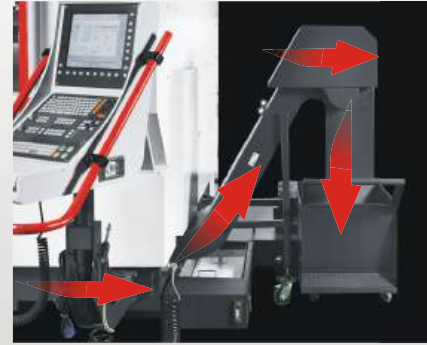

In the chip removing function, the design of chip conveying system is simple and efficient. During the working process, the chips are carried along with the massive amount of Coolant from the Chip Removing Mechanism to the Crawler-type Chip Conveyor in front of the machine. Through such Crawler-type Chip Conveyor, the chips will be discharged to the Chip Collector at the right side of the machine for the user to clean up the chips easily and conveniently.

## Recommended Chip Conveyor

● Good ○ Fair x Bad

Material		Steel	Cast Iron	Alu./Non-ferrous Metal	Mixed Chips
Shape of Chip					
Crawler-type Chip Conveyor	Scraper-type (standard)	Cast Iron (Heavy)	x	●	x
		Alu. (floating)	x	x	●
	Chain Panel Type	●	○	x	○

## Crawler-type Chip Conveyor (Scraper type) OP



## Crawler-type Chip Conveyor (chain plate type)

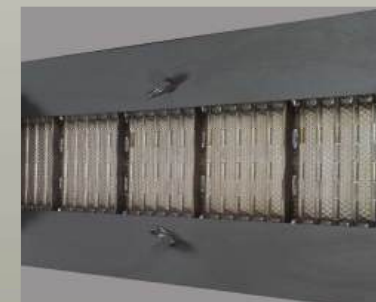

# Coolant System

Coolant System out of Spindle



## Integrated High-efficient Coolant System



Circular water Flushing System



Worktable / Clamp Chip Flush Device



Tool / Workpiece Chip Flush Device





## Control System Unit

The machine is equipped with the modern 5-axis Controller. The Heidenhain TNC-640 System (TNC-640 is for optional) is an innovative software provided to enhance the accuracy, production efficiency and safety during the machining process. In the meantime, it is also fitted with a network port to achieve fast and direct connection with external network.



Anti-collision Software System (for TNC-640 only)



**DCM**(Software Function)  
Dynamic Collision  
Monitoring for TNC-640

Anti-collision (for TNC-640 only)



## User-friendly Ergonomics and Space Saving

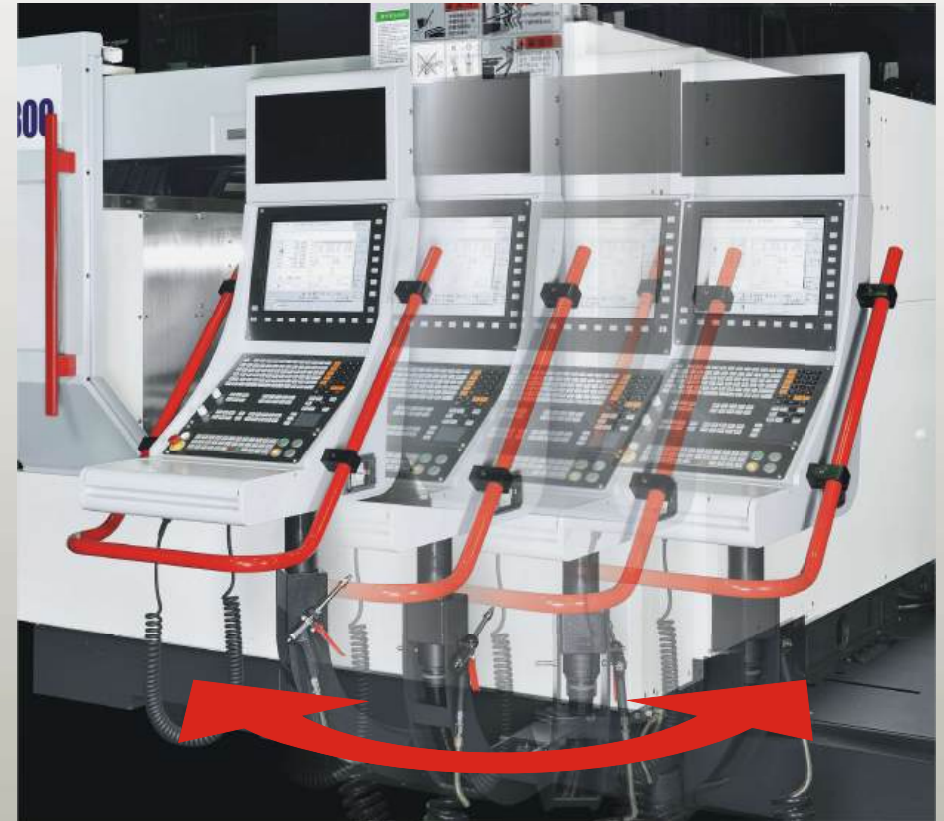

- The Operation panel can be adjusted up and down according to the physical height of human body.
- The Operation panel is fitted with red handle for executing left and right rotation easily.
- This unit is also provided with ergonomic storage box and operation table for easier operation.
- The movable hand wheel and chip flushing air gun are located at accessible position.

## Intellectual Control System

## Main Specifications of Control System

The Intellectual Controller represents the maximum production efficiency, machine accuracy and optimal operation maneuverability. It is the symbolic quality and performance offered by Heidenhain and Siemens, which are the leader of the global market.



Heidenhain Controller



Siemens Controller

	Heidenhain TNC-640	SIEMENS 840Dsi OPERATE
Control Axis	⊕5	⊕5
Min. Input Unit	0.001/0.0001 (option)	0.001 / 0.0001(option)
Color Screen	19.0"	15.0" / 19.0"(option)
Hand Wheel	⊕HR510	future life technology co.ltd
Adjustable Feed Rate	⊕	⊕
Memory Capacity	HDR with 160GB (option) /SSDR with 21GB	10MB / 6GB(option)
Tool Compensate Quantity	32767	600
Parameter Program Revise	⊕Q parameters	⊕
RS232C Interface	⊕	⊖
Network Interface	⊕	⊕
UK System/ Metric System Conversion	⊕	⊕
Program Synch.	⊕	⊕
Rigid Tapping	⊕Cycle 207	⊕Cycle 84
Cylinder Milling Rotation	⊕Cycle 251~Cycle257	⊕MILL
Boring Rotation	⊕	⊕
Workpiece Coordinate Rotation	⊕Cycle 10/Cycle 19	⊕ROT & AROT
Workpiece Coordinate Conversion	⊕Cycle 7	⊕TRANS & ATRANS
Geometric Coordinate Mapping	⊕Cycle 8	⊕MIRROR & AMIRROR
Tool Radius Compensate	⊕Tool table	⊕
Program Suspend Time	⊕Cycle 9	⊕
Spindle Position	⊕Cycle 13/ M19	⊕SPOS
Graphic Program	Heidenhain , ISO	Shop Mill
Graphic Simulate	⊕	⊕

# High Performance Layout (1)

## Safety Door System



- To ensure the safety of the operator, the working program cannot be started if the Safety Door is not closed.
- If the Safety Door is opened during the working process, the machining program will stop to protect the safety of the operator

## Pneumatic and Lubricant system



- The Lubrication System and the Compressive Air Unit is fitted with high-performance and high-quality components to ensure the reliability of the system.

## Working Status Indicator (LED)



## Coolan Gun



## Through Spindle Coolant System

OP



- Additional Spindle Center Coolant System is provided for the coolant to pass through the Spindle center and then inject from the tool tip. It can be used to cool down the Workpiece and the Tool edge directly for carrying away the cutting heat in order to ensure the machining quality. It is suitable for processing the parts with deep hole.

## LED Illumination Lamp

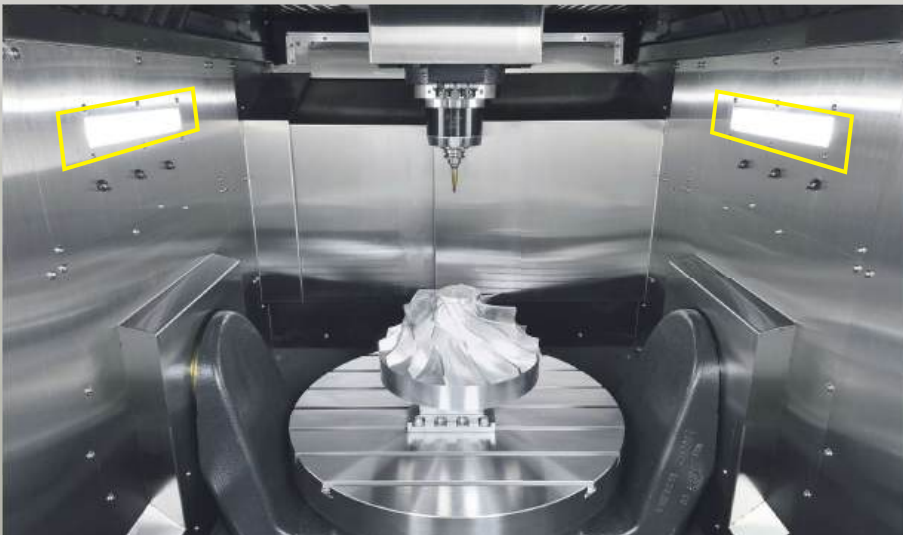

- The internal side of the machine is provided with high-luminance working lamp for the operator to load/unload the Workpiece and execute the measuring work.
- The provided working lamp is designed with the function to resist against dust, water and explosion.
- The working lamp is designed with angled light domain function to concentrate the light to the working area.

## High Performance Layout (2)

Grease type lubricant system



3-axis ballscrew cooling system

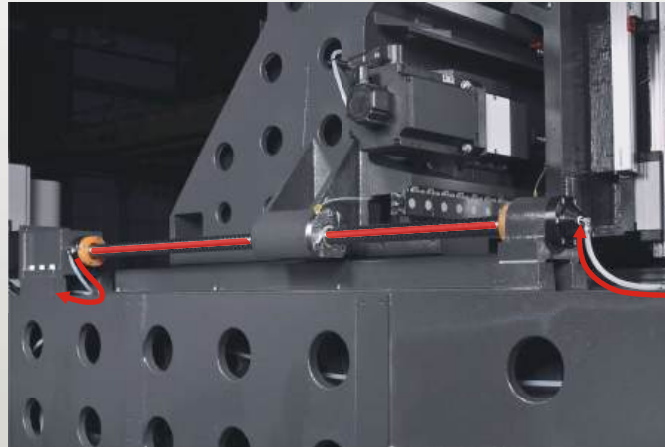

Rotary Window **OP**

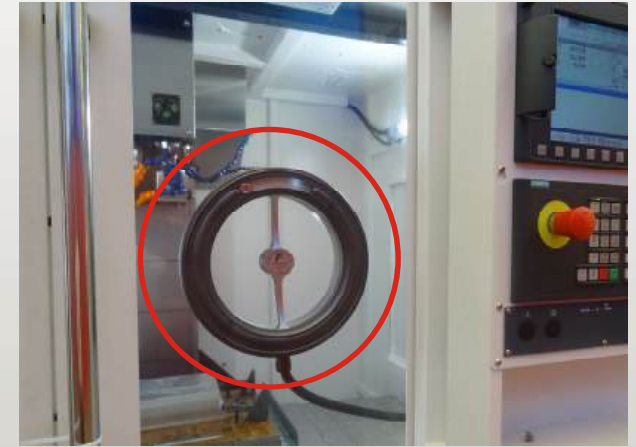

Oil demister system **OP**



Spindle External Air Blow System

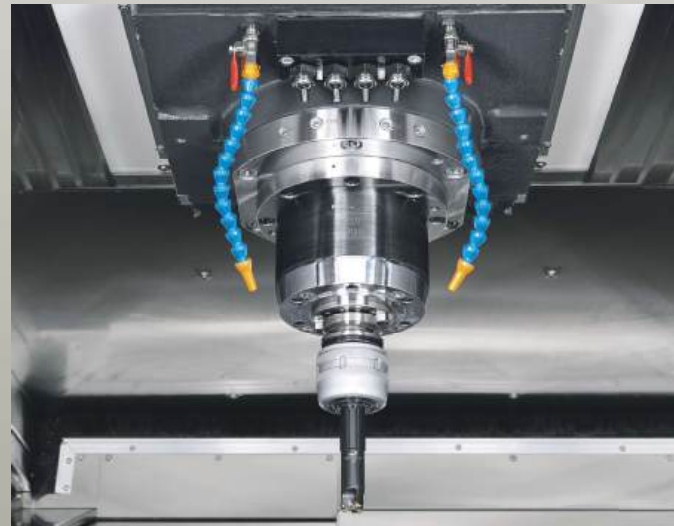

Manual top cover



## Operability and Accessibility

### Operability of A, C Axes

Easier for loading and unloading the Workpiece



### Convenient for installing the Tool from the Magazine



### Convenient for unloading the Tool from the Magazine



# Convenient and simple maintenance design (back-mounting type)

Pneumatic and Lubricant system



ATC maintenance door



Tool Holder



A/C Unit



Electrical Box

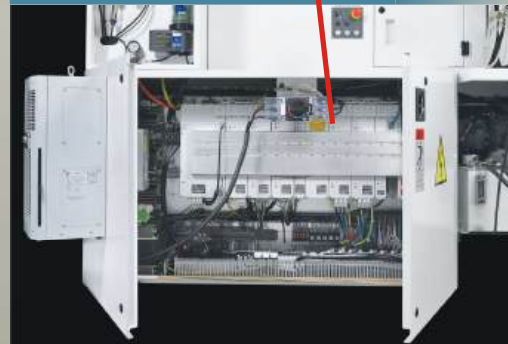

## Tool Measuring Laser System OP

Based on continuous Tool monitoring figures, the user will be able to discover the wearing, notching and breaking before the Tool is damaged in order to ensure the stabilized production quality to avoid the subsequent losses and reduce the defective item and the machining cost required for repairing. The measuring function will operate automatically to achieve effective monitoring, including the unattended machining.

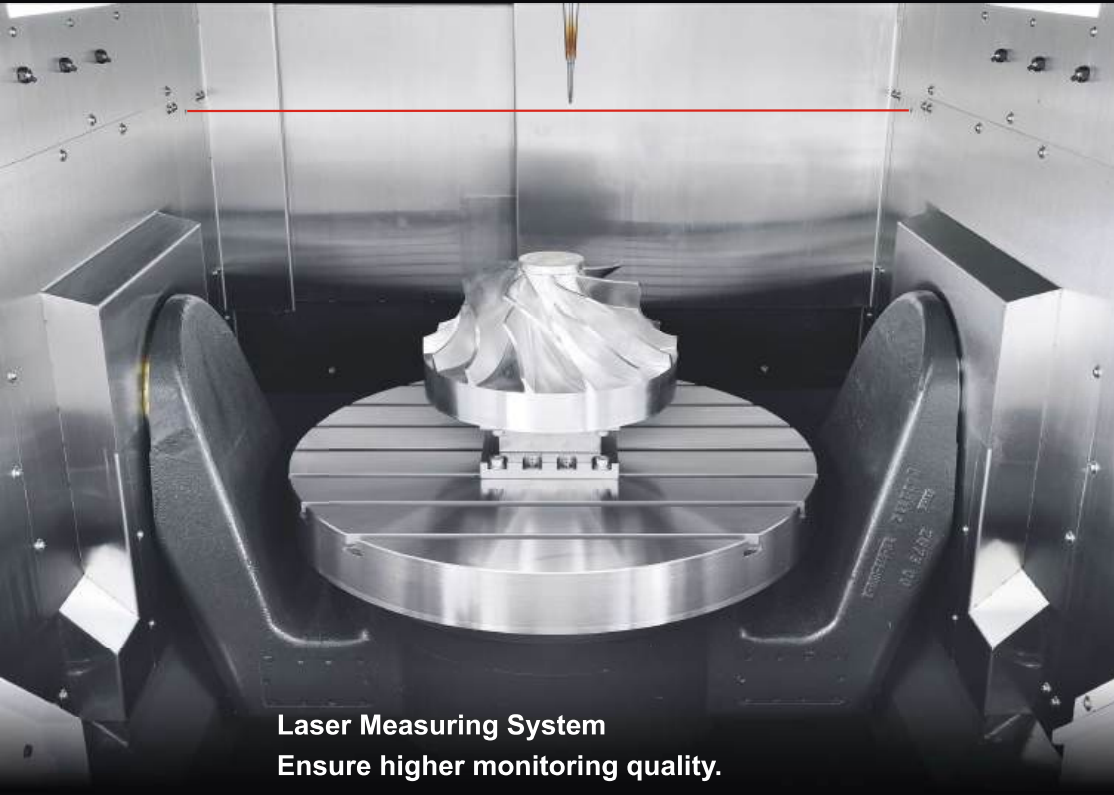

**Laser Measuring System**  
Ensure higher monitoring quality.  
Higher measuring accuracy and precision.  
Detect the wearing and tearing.

It has the following advantages:

- Shorten the non-production time.
- Execute unattended machining.
- Reduce the defect rate.
- Enhance the production efficiency.
- Continuous stability in production quality.

## Radio workpiece measuring system OP

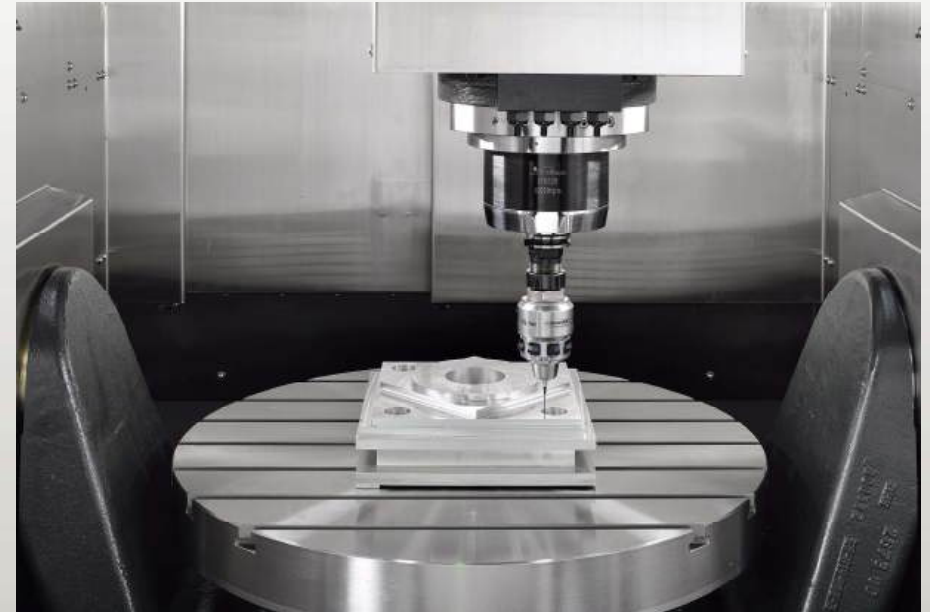

### Features:

- The workpiece shall be allowed for clamping at any position.
- The probe shall be used to detect the surface of Workpiece, both holes or both protruding platform to confirm the misalignment of the Workpiece.
- The turntable of CNC Digital Control System is to compensate the misalignment. In addition, you may also turn the working bench to compensate the misalignment.

## Spindle thermal compensation system OP

Before compensation



After compensation

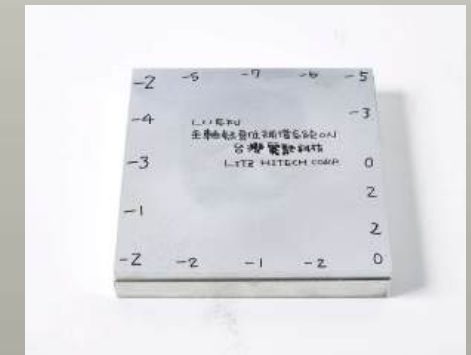

# High Accuracy Machining Test

The Dynamic Cutting Test should be executed for the LU-Series 5-Axis Machining Center according to NAS979 standard in order to inspect the high-accuracy performance of the machine.



## TCP Calibration function

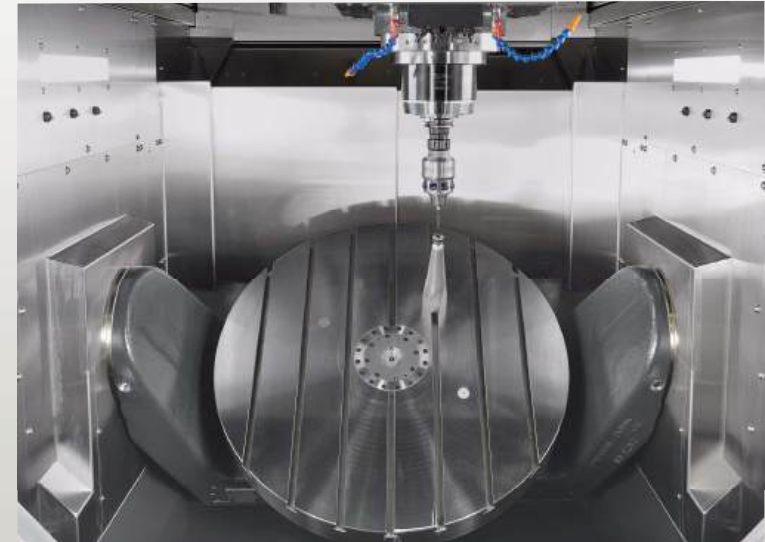

- The Working table is equipped with Heidenhain TS-740 to execute the centering calibration. By using high-accuracy measuring probe and standard measuring spherical ball with Heidenhain Measuring Software, the user can test the centering error value of the Working table and then compensate the error in the Control System in order to maintain the centering accuracy of the Working table.

## Rotary Axis Laser Accuracy Test



Roundness (when inhibiting 5 axes at the same time) (NAS 979 standard)	<b>Roundness (tested value) → 0.008mm</b>	
	<b>Cutting conditions:</b>	
	Cutting Object (JIS)	A7075 (alu. Alloy)
	Tool	Ultra-hard End-mill Tool - Ø 40mm (double-edge Tool)
	Spindle Speed	2000 rpm
	Milling Speed	2000 mm/min
	Workpiece Dimensions	Ø216mm x Ø250mm x 63.5mm (H)



## CAM Solution to High Efficient Manufacturing



### Innovative CAM Technology from the 5-axis Pioneer

Although 5-axis milling is one of the most challenging forms of CNC machining, OPEN MIND's hyperMILL® CAM software simplifies the process. This enables programmers to generate 5-axis NC programs quickly and easily with reduced machining times, improved process reliability and high quality surface finishes.

OPEN MIND's innovative 5-axis technology stands above other solutions due to its simple and user-friendly programming and also its reliable and intelligent algorithms for collision detection and avoidance.

- Multiple tilt strategies are available: 3+2, automatic indexing and 5-axis simultaneous machining.
- A broad spectrum of machining strategies are available for surfaces, cavities and special machining tasks.
- Special strategies for impeller and blisk, single blade, and tube machining

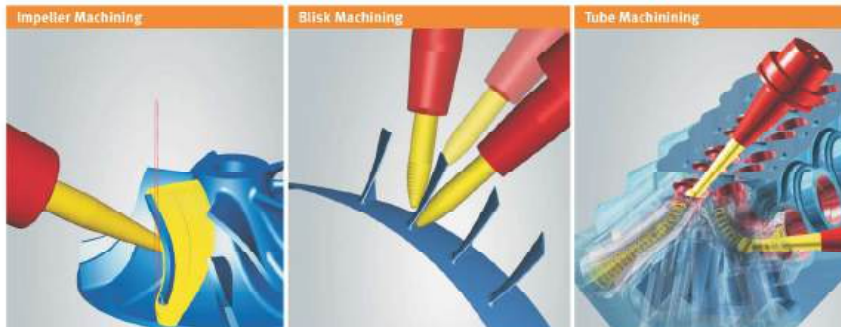

# PowerMILL

A leading brand in 2-5 axis high-speed machining CAM System

Strategic partner operation between LITZ HITECH and DELCAM



Being a leader in 2-5 axis high-speed machining CAM System, the PowerMILL is affirmed by the market in its operability, efficiency and functionality.

### 5-Axis Synchronous Machining – PowerMILL 5-Axis



Nowadays, Delcam continues its strength in serving as a leader in the 3-axis CAM technology and its own 5-axis machining center. The PowerMILL 5-axis machining system is developed to meet the demand of the complicated machining market. By incorporating the latest machine action, it can support the post-treatment for all types of 5-axis machines and the machine action dynamic simulation, complete with the user-friendly interface to help the user adapt to the machine quickly. In the meantime, PowerMILL also provides over-cutting protection, automatic Spindle offsetting and optimal Tool unclamping link. In this way, the 5-axis machining program is safe, easy for operation and efficient.



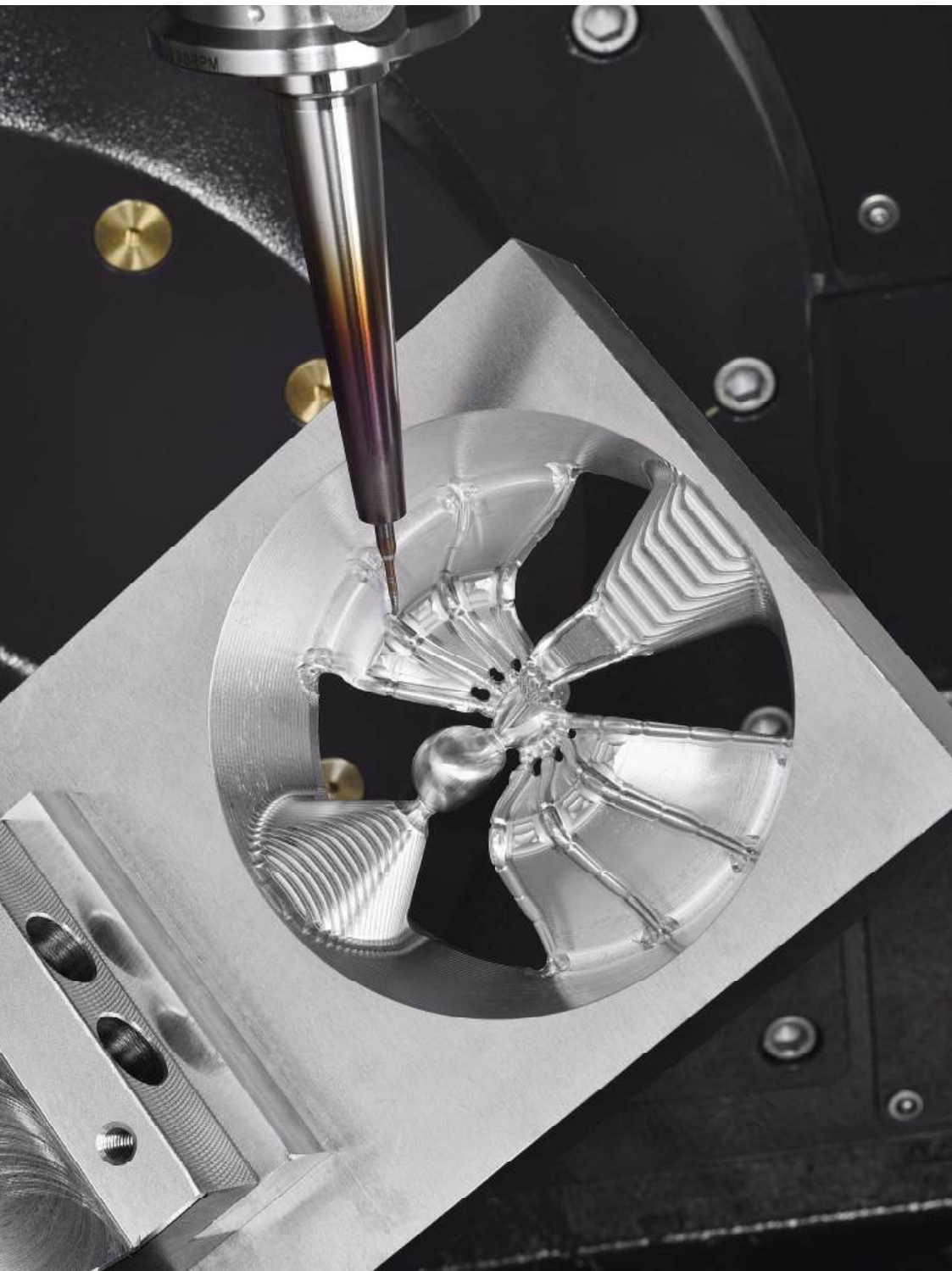
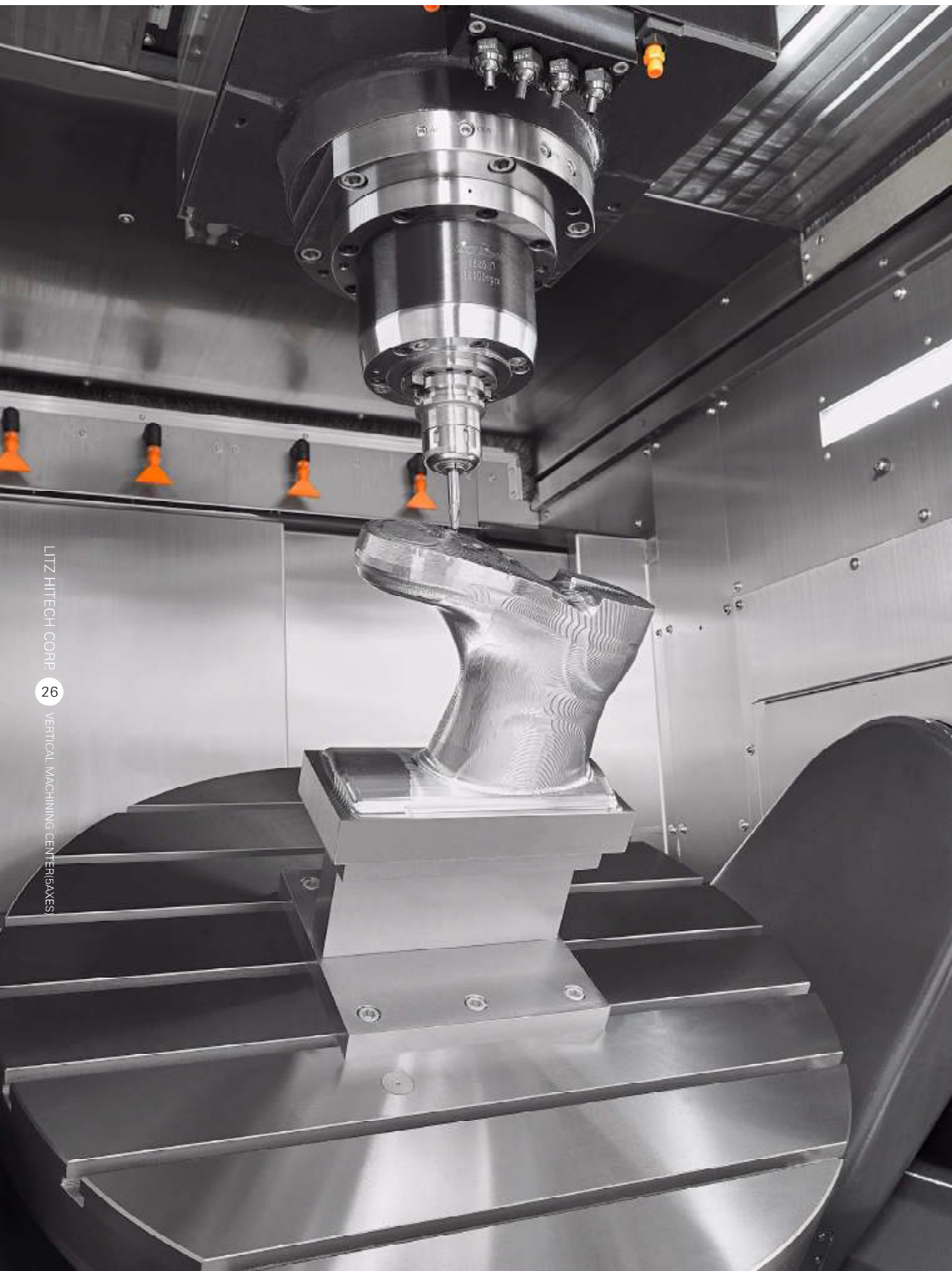

### 3-Axis Machining Center



#### Rigid Positioning Working Table

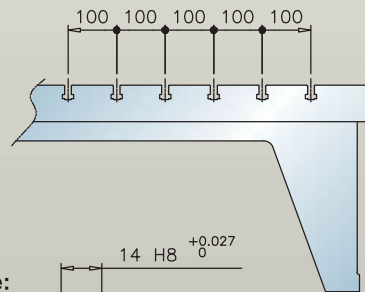

#### T-shape Groove:

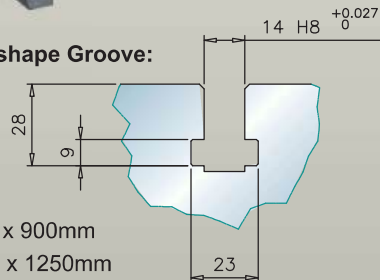

LU-800A/B : Working Table dimensions - 900 x 900mm

LU-1200B : Working Table dimensions - 1250 x 1250mm

Working Table Load Capacity : 700 KG

### 5-Axis Machining Center



#### NC Rotary Working Table



LU-800A/B	LU-1200B
Working Table Dimensions : $\varnothing$ 800mm	Working Table Dimensions : $\varnothing$ 1150mm
Rotation Angle : $\pm 120^\circ$	Rotation Angle : $\pm 120^\circ$
A-Axis Rotation Speed : 75rpm	A-Axis Rotation Speed : 26rpm
A-Axis Drive Mode : Direct drive	A-Axis Drive Mode : Direct drive
C-Axis Rotation Speed : 100rpm	C-Axis Rotation Speed : 50rpm

# Outline Dimensions

Unit: mm

## LU-800A/B

### Description of components:

- ① LU-800 Main Body
- ② Coolant tank
- ③ Crawler-type Chip Conveyor
- ④ Chip trolley
- ⑤ A, C-axis Water Chiller
- ⑥ Coolant Through Spindle (CTS) **OP**
- ⑦ Transformer Unit **OP**
- ⑧ Operation Box System
- ⑨ Hydraulic Pump Unit
- ⑩ Oil Cooler Unit (X/Y/Z Axis / Direct Drive Spindle)
- ⑪ Water Chiller (Built-in Spindle) **OP**

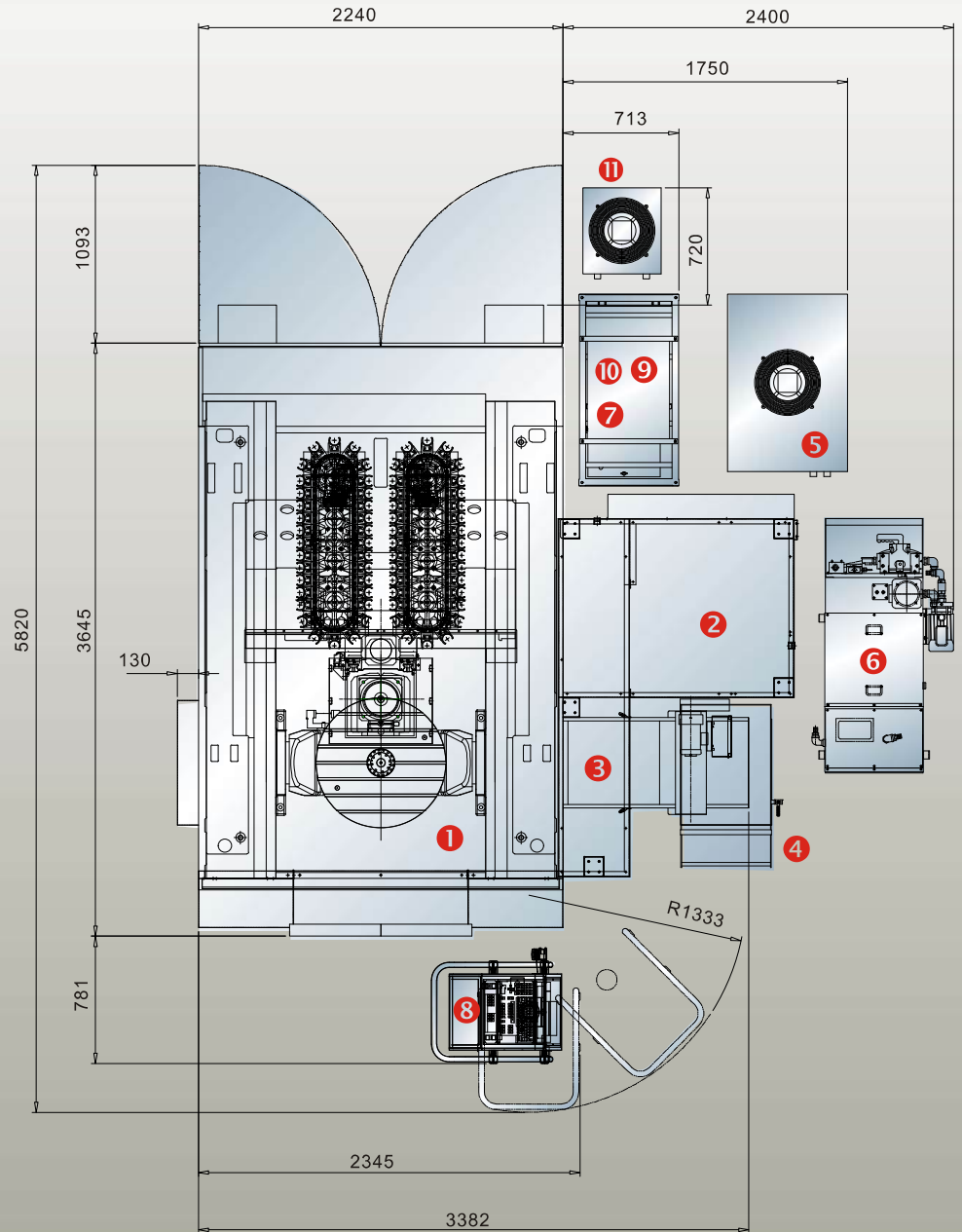
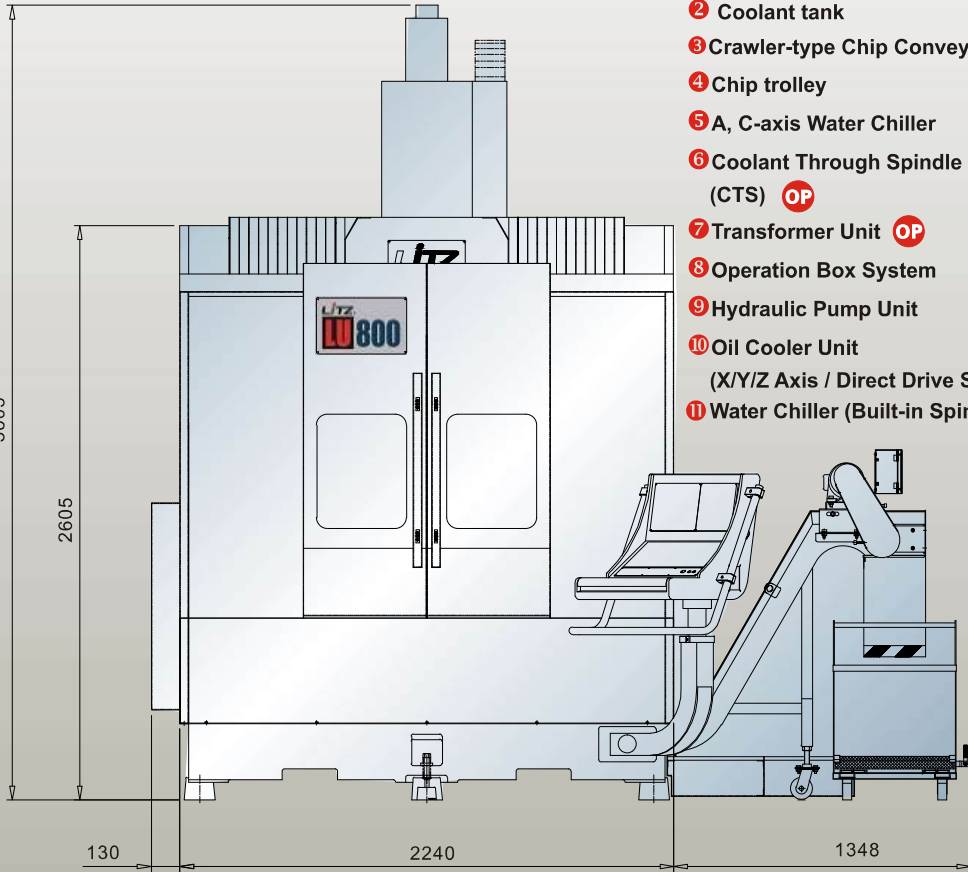

# LU-1200B

Description of components:

- ① LU-1200 Main Body
- ② Coolant tank
- ③ Crawler-type Chip Conveyor
- ④ Chip trolley
- ⑤ A, C-axis Water Chiller
- ⑥ Coolant Through Spindle (CTS) **OP**
- ⑦ Transformer Unit **OP**
- ⑧ Operation Box System
- ⑨ Hydraulic Pump Unit
- ⑩ Oil Cooler Unit (X · Y · Z Axis / Direct Drive Spindle)
- ⑪ Water Chiller (Built-in Spindle) **OP**

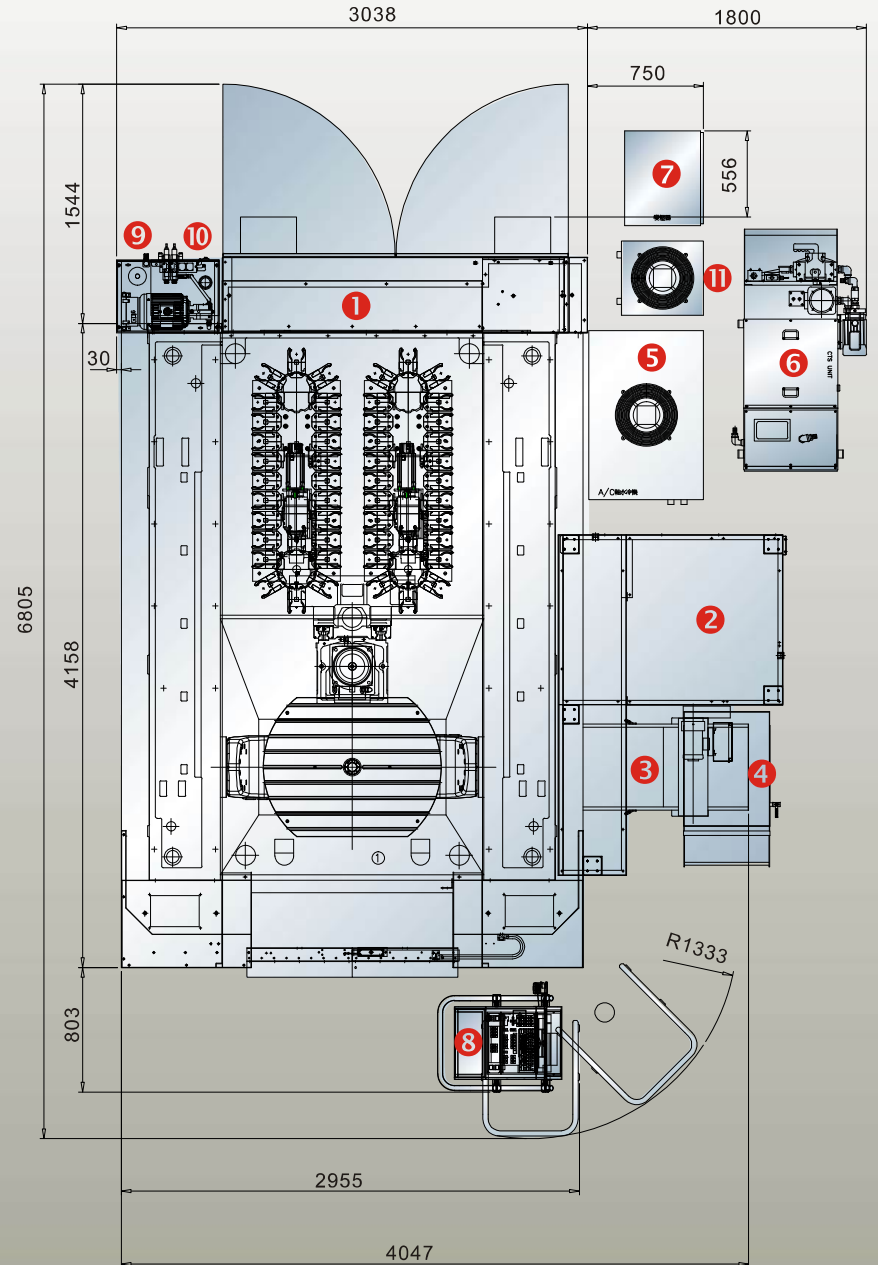
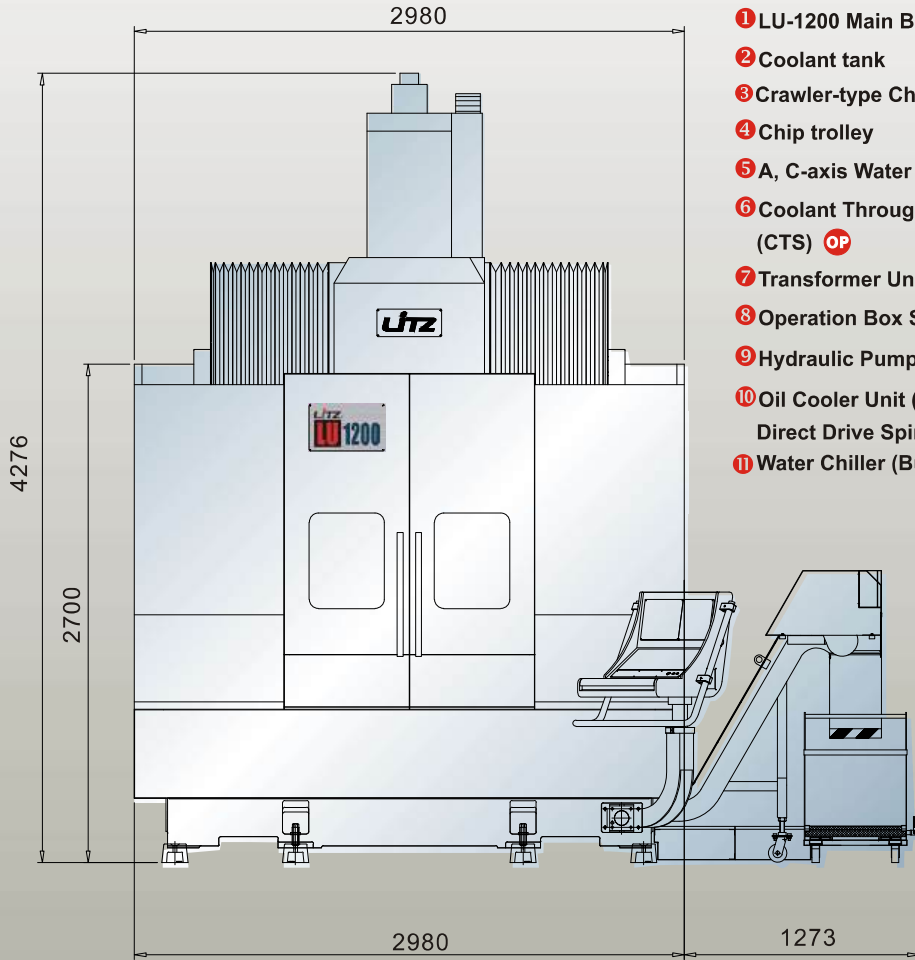

## Worktable Dimensions (LU-800A/B)

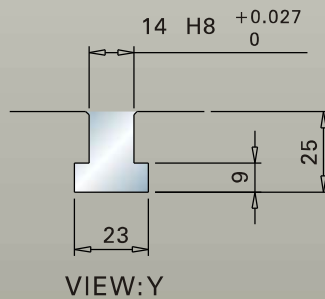
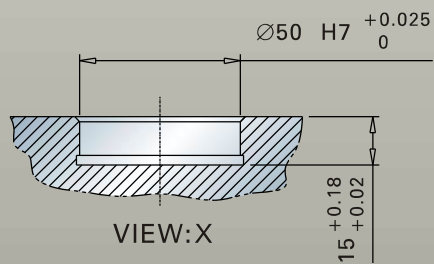
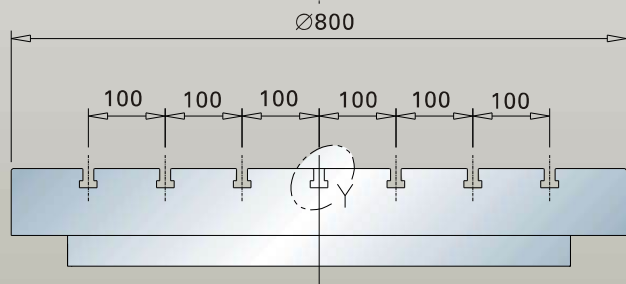
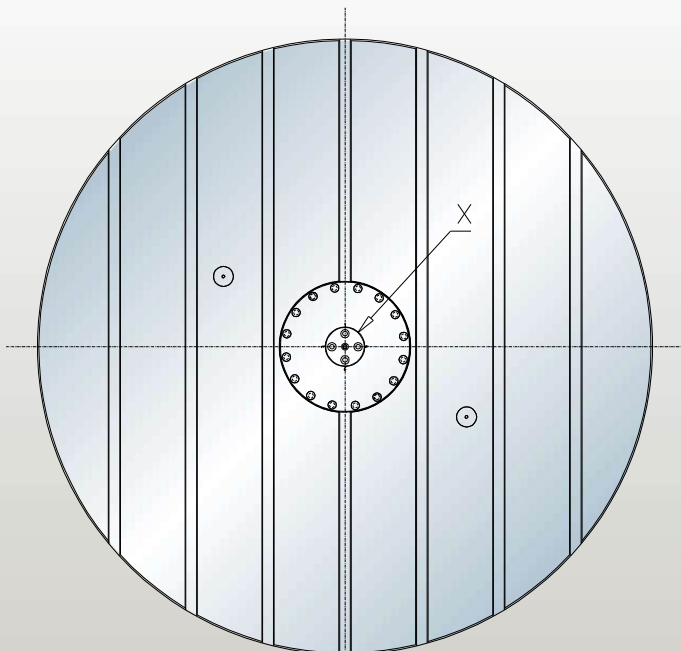

## Tool Dimensions

Unit: mm

### LU-800A

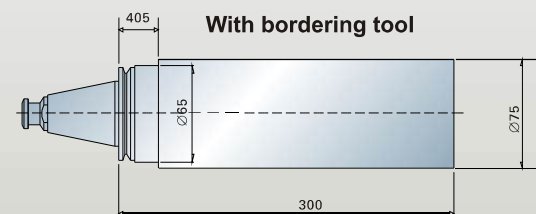
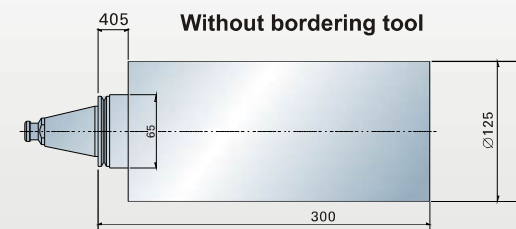

### LU-800B

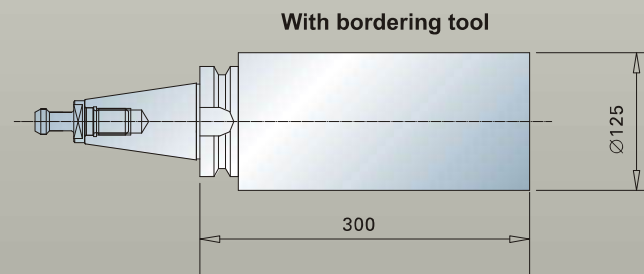
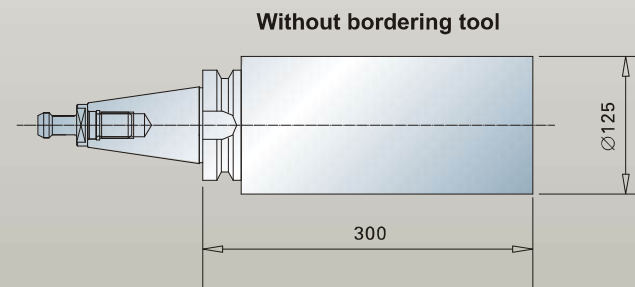

Note: The max. tool diameter of LU-800B #50 with and without bordering tool will be the same.

## Worktable Dimensions (LU-1200B)

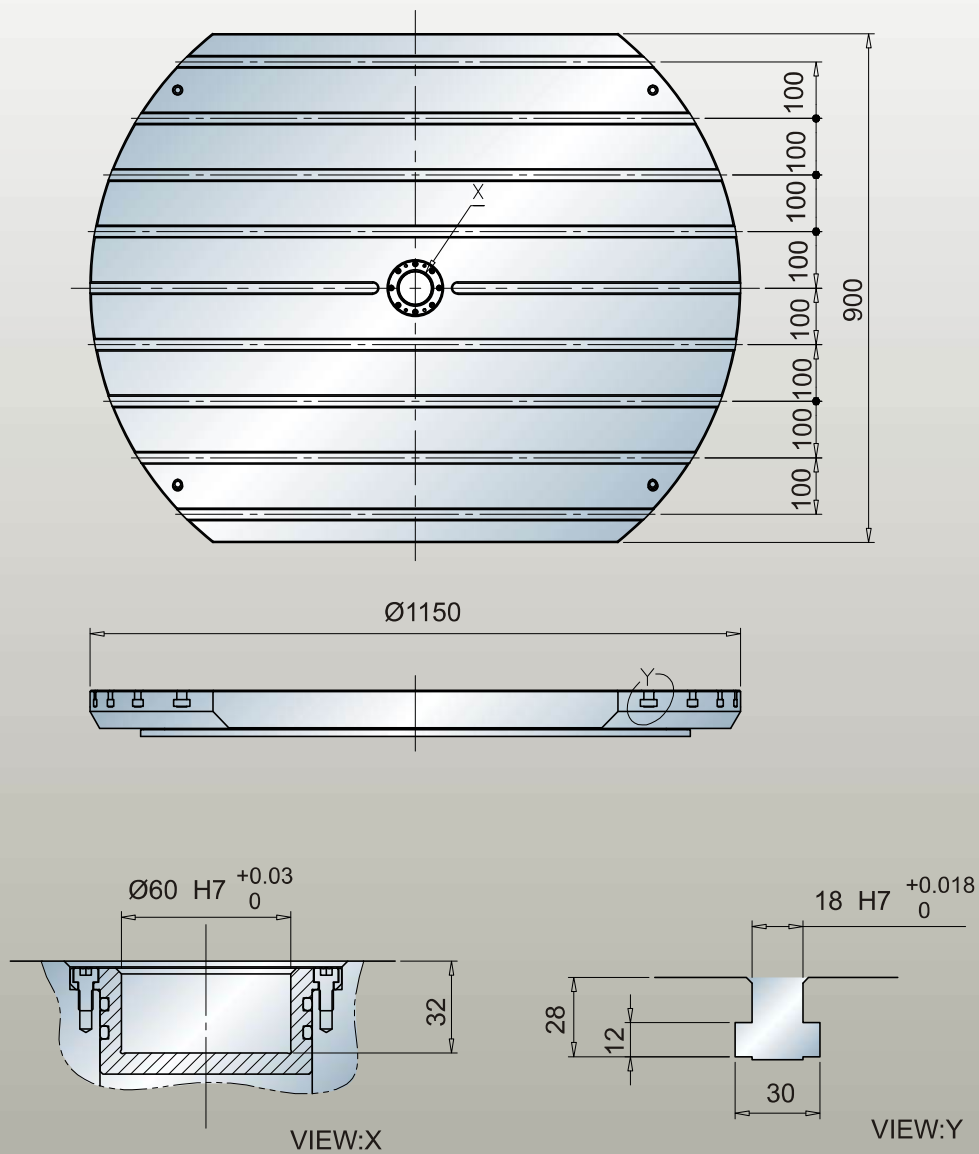

## Tool Dimensions

Unit: mm

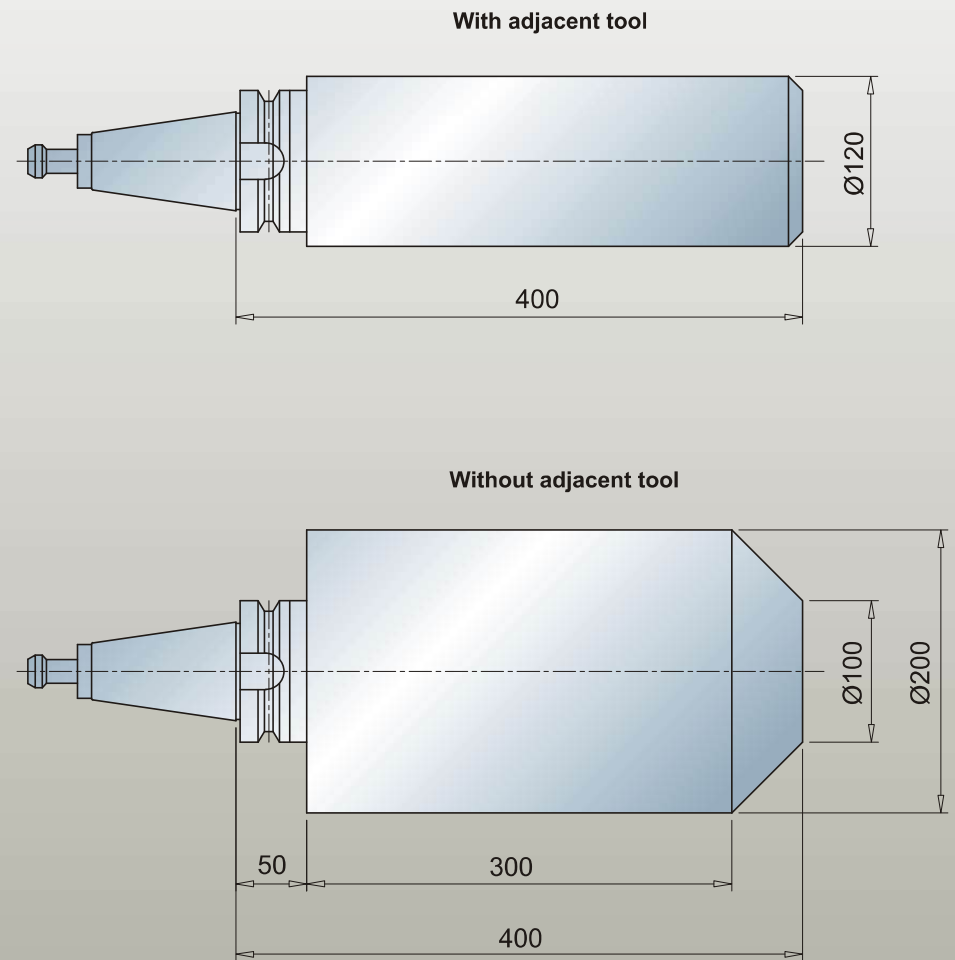

# Cutting Area and Interference Area (LU-800A/B)

Unit: mm

## Cutting Area

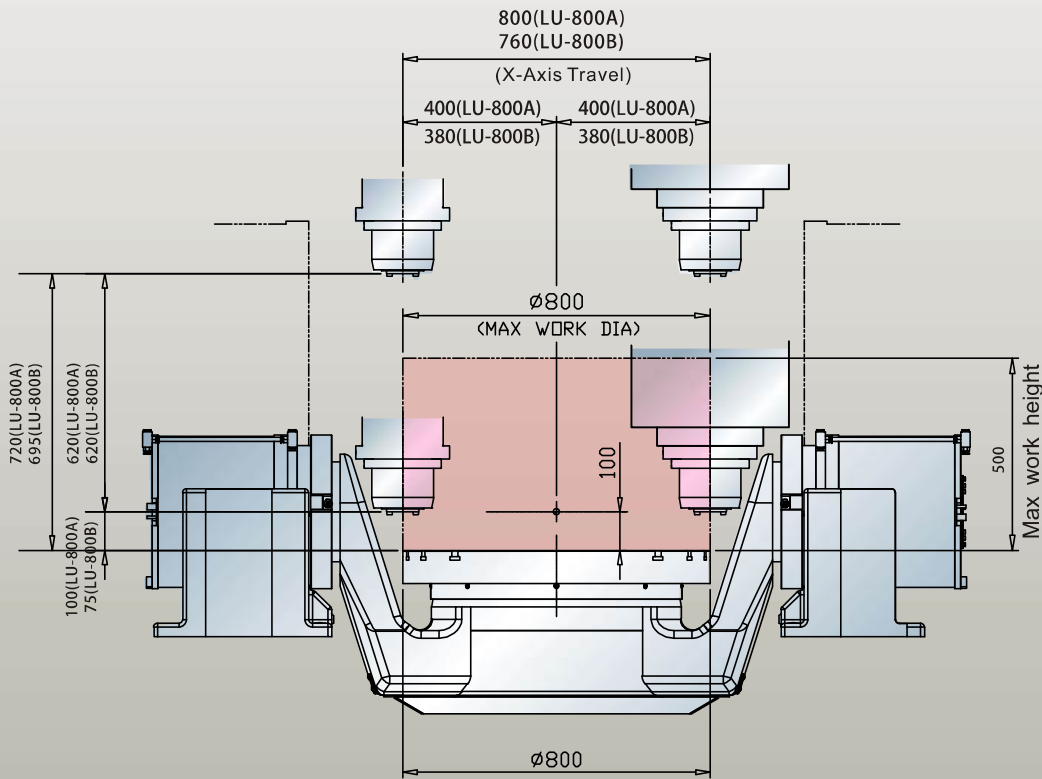

## Intervention Area

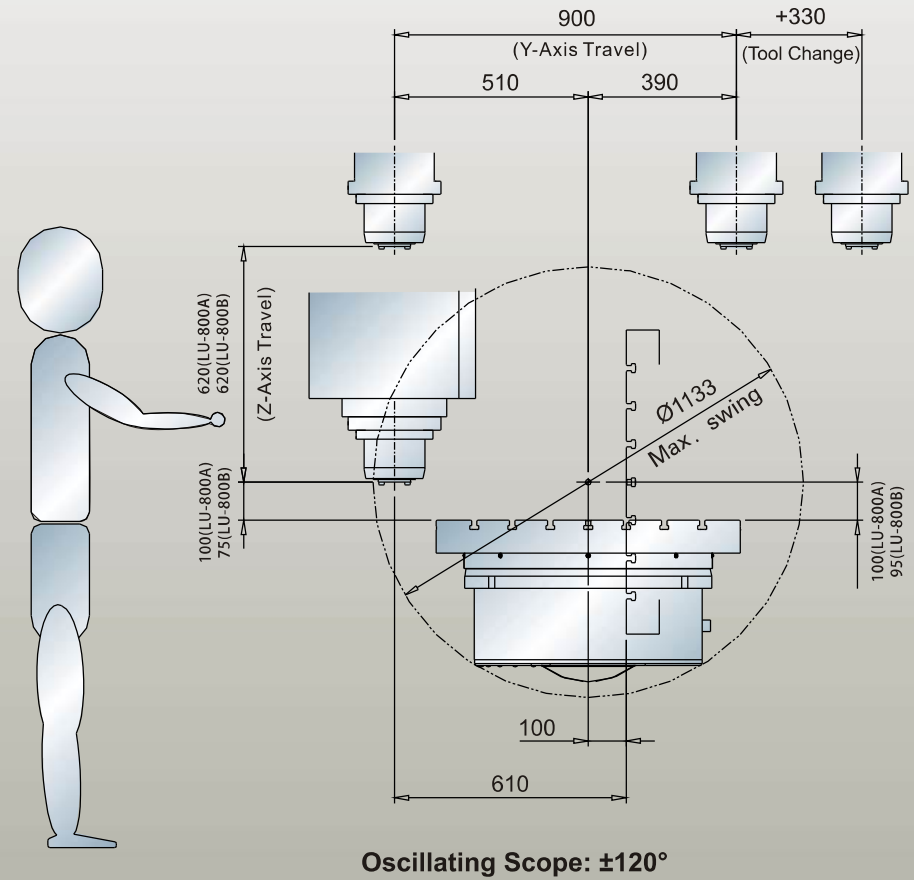



# Cutting Area and Interference Area (LU-1200B)

Unit: mm

## Cutting Area

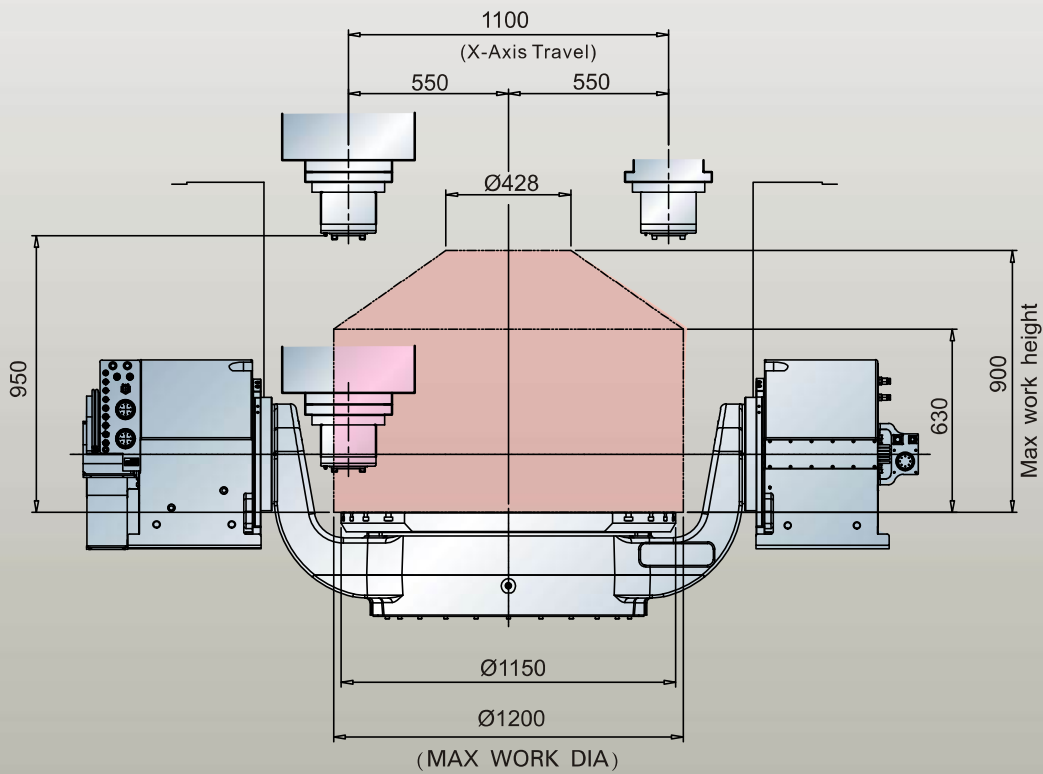

## Intervention Area

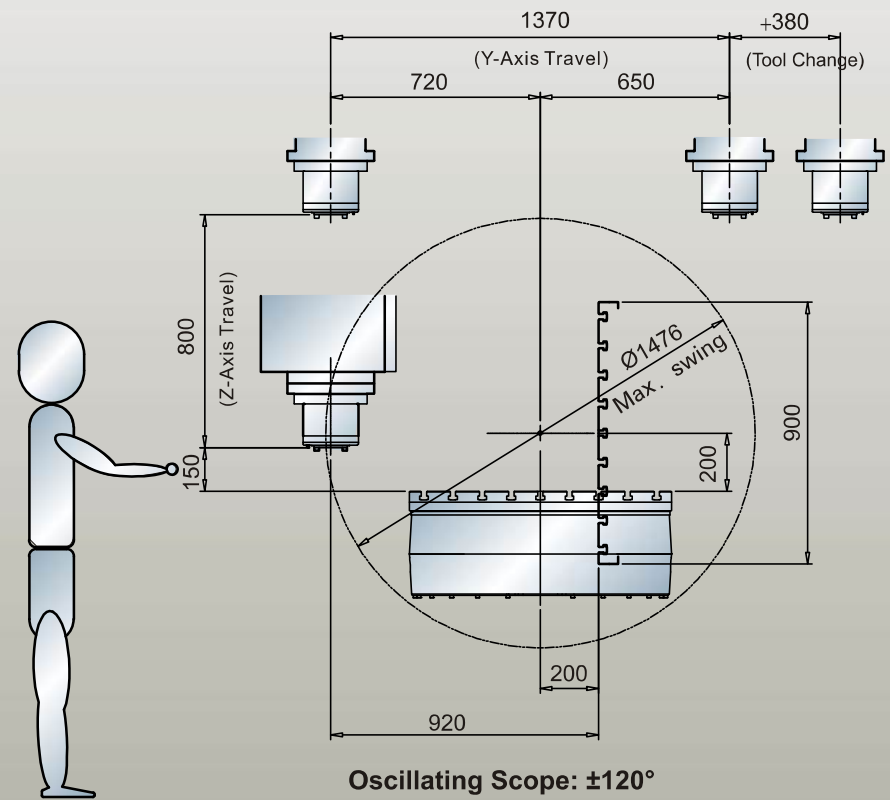

## Technical Data

### Machine Specifications

		LU-800A	LU-800AT	LU-800B	LU-1200B
X-Axis Travel	mm	800	800	760	1100
Y-Axis Travel	mm	900+330	900+330	900+330	1370+380
Z-Axis Travel	mm	620	620	620	800
Distance from Spindle Nose to Table surface	mm	100-720	50-670	75-695	150-950
Worktable Dimensions	mm	Ø800	Ø800	Ø800	Ø1150 x 900W
Worktable Load	kg	1000	1000/500 (Milling/Turning)	1000	2000
<b>Feed System</b>					
Rapid Feed (X/Y/Z)	m/min	48/48/48	48/48/48	48/48/48	48/48/48
Cutting Feed (X/Y/Z)	m/min	0.001-20	0.001-20	0.001-20	0.001-20
<b>Rotary Axis</b>					
A-Axis Rotation Angle	degree	±120°	±120°	±120°	±120°
C-Axis Rotation Angle	degree	360°	360°	360°	360°
A-Axis Max. Speed	rpm	75	75	75	26
C-Axis Max. Speed	rpm	100	800	100	50
<b>Spindle System</b>					
Spindle Transmission type		Direct Drive (standard) / Built-in (OP) / Two Stage Gearbox			Direct Drive (standard) / Built-in (OP)
Spindle Speed (max.)	rpm	12000	18000	8000	8000
Spindle Power (continuous/S6-40%)	kw(HP)	17/23kw	30/38kw	18/25kw	27/37kw
Max. Torque	Nm	240	87.9/123.8	700	400
Tool Handle Spec.		#40 / HSK A63	#40 / HSK63T	#50 / HSKA100	#50 / HSKA100
<b>ATC System</b>					
Magazine Capacity	Set	32T (standard)	32T (standard)	24T (standard)	24T (standard)
Tool Change Method		DRUM	DRUM	DRUM	DRUM
Max. Tool Dis./with Adjacent tool	mm	Ø75 / Ø125	Ø75 / Ø125	Ø125 / Ø125	Ø125 / Ø200
Max. Tool Length	mm	300	300	300	400
Max. Tool Weight	kg	7	7	15	15
<b>Control System</b>					
Controller		TNC-640	840D	TNC-640	TNC-640
Chip Conveyor		Chain type	Chain type	Chain type	Chain type
Machine Occupancy(L x W x H)	mm	4528x2240x3605	4528x2240x3605	4528x2240x3605	5600x2980x4196
Machine Weight	kg	21000	21000	21000	32000

■ All pictures contained in this catalogue are for reference only.

■ LITZ shall reserve all right to change the appearance or to suspend the specifications or options of machines

## Optional List

	LU-800A	LU-800AT	LU-800B	LU-1200B
<b>Spindle</b>				
Spindle speed-12000RPM (LU-800)	●	●	---	---
Spindle speed-15000RPM (LU-800)	○	○	---	---
Spindle speed-8000RPM (LU-1200)	---	---	●	●
Spindle Oil Cooler	●	●	●	●
Spindle Motor Cooling System	●	●	●	●
Coolant Through Spindle (CTS)	○	●	○	○
Spindle Air Seal System	●	●	●	●
ZF Gearbox	---	---	●	○
<b>Cooling System</b>				
Worktable Washing System	○	○	○	○
Spindle Programmable Air Blow System	●	●	●	●
Oil Path Tool Handle Stopper	○	○	○	○
Circle Injection System	●	---	●	●
Coolant Cooling System	○	○	○	○
<b>Chip Conveying System</b>				
Chain-type Chip Conveyor	●	●	●	●
Chip Collector	●	●	●	●
Water Gun	●	●	●	●
Air Gun	●	●	●	●
Manual top cover	●	●	●	---
Programmable Top Cover	○	○	○	●
Full Enclosure	●	●	●	●
<b>Measuring System</b>				
Laser Tool Length Measuring	☆○	☆○	☆○	☆○
Wireless Workpiece Measuring	○	○	○	○
<b>Worktable Unit</b>				
Worktable Clamp Air Hydraulic Source	☆○	☆○	☆○	☆○
Large Worktable-Ø800m/m (LU-800)	●	●	●	---
Large Worktable-Ø1150m/m (LU-1200)	---	---	---	●
<b>Safety System</b>				
Front Door / Safety Switch/ATC Backdoor	●	●	●	●
CE Safety Specification	○	○	○	○
<b>ATC Unit</b>				
Auto Tool Change Mechanism (ATC)	●	●	●	●
Tool Spec. BBT-40	●	●	---	---
Tool Spec. BBT-50	---	---	●	●
Tool Magazine Capacity - 32T	●	●	---	---
Tool Magazine Capacity - 24T	---	---	●	●
Tool Magazine Capacity - 32T + 32T	○	○	---	---
Tool Magazine Capacity - 24T + 24T	---	---	---	○
<b>3-Axis Transmission System</b>				
3-Axis Roller Type Linear Guideways	●	●	●	●
3-Axis Linear Scale	●	●	●	●
A-Axis Linear Scale	●	●	●	●
C-Axis Linear Scale	●	●	●	●
Z-Axis Motor System with Brake	●	●	●	●
<b>Electrical Components</b>				
Worklight (LED)	●	●	●	●
Alarm light (LED)	●	●	●	●
M30 Automatic Shutdown System	●	●	●	●
Air conditioner	●	●	●	●
<b>Controller</b>				
Siemens 840Dsl (5-Axis/5-Interactive)	○	○	○	○
Heidenhain TNC-640 (5-Axis/5-Interactive)	●	●	●	●
Transformer Unit (for 220V)	☆○	☆○	☆○	☆○
Anti-Collision Software (for TNC-640 only)	☆●	☆●	☆●	☆●
Centering Calibration Function	☆○	☆○	☆○	☆○
<b>Others</b>				
Oil demister system	○	○	○	○
Rotary Window	☆○	☆○	☆○	☆○

● : Standard ○ : Optional ☆ : Inquiry Needed

# Total Production Solution

Highly efficient manufacturing fashion, equipped with high performance control system. The high speed contouring capability can achieve best possible surface quality under most demanding machining cycle time. Highly dynamic five axes machining provides solution for complex tasks.



## Heidenhain & Siemens Control System

iTNC530 / 840D  
Ideal for high-end application CNC system. Modular, open, flexible operating interfaces are the highlight of the controller. Programming and visual structure can be integrated with network systems.



Litz Hitech & Open Mind, the CAM company  
The strategic alliances



The monitoring & collision test within work range



MST Tools (Japan)



## Litz Hitech LU Series

5 Axes Series employs U shape base with dual-support A/C axes rotary worktable's high rigidity mechanism. The machine is equipped with 12000RPM direct-drive high speed spindle. High durable roller type linear guideways, 3 axes high precision linear scales along with other high quality components brings out the excellences of the 5 axes simultaneous control. Mill, drill, tap, spiral, irregular and other complex machining can be easily achieved.

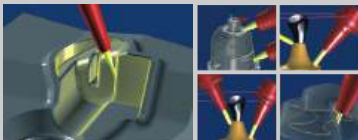

# Technical Support Global Presence



## SALES & DISTRIBUTION NETWORK



www.litzhitech.com



Distributor

Manufacturer

**LITZ**



**LITZ HITECH CORPORATION**

NO.18 Yu 9 Rd., Yu Shih Ind.Park, Tachia District,  
Taichung City, Taiwan.

TEL: +886-426815711

FAX: +886-426815108

E-mail: sales@litzhitech.com

http://www.litzhitech.com



**LITZ MACHINE TOOL (JIAXING) CORP.**

NO.1398 He Feng Road., Jiaxing City, Zhejiang China.

TEL: +86-573-82222735

FAX: +86-573-82222739

E-mail: linfen.jl@litzhitech.com

http://www.litzchina.cn

» For more information, please visit LITZ website.